



This work is licensed under a Creative Commons Attribution License (CC BY 4.0).

## Research article

[urn:lsid:zoobank.org:pub:4F834ADD-57E7-4CE3-B16A-127F1BE4AE14](https://zoobank.org/pub:4F834ADD-57E7-4CE3-B16A-127F1BE4AE14)

# Review of the Asian Thaumastodinae (Coleoptera, Byrrhoidea, Limnichidae), with a phylogeny of the genera

Hiroyuki YOSHITOMI

Ehime University Museum, Bunkyo 3, Matsuyama, 790-8577 Japan.

Email: [hymushi@agr.ehime-u.ac.jp](mailto:hymushi@agr.ehime-u.ac.jp)

[urn:lsid:zoobank.org:author:744FA6FC-2D84-41B7-8A6C-C1611CC68EE1](https://zoobank.org/author:744FA6FC-2D84-41B7-8A6C-C1611CC68EE1)

**Abstract.** The Asian species of the subfamily Thaumastodinae Champion, 1924 are reviewed. Seven new species are described: *Acontosceles borneensis* sp. nov., *Pseudeucinetus papuanus* sp. nov., *Mexico ogasawaraensis* sp. nov., *M. baliensis* sp. nov., *M. papuanus* sp. nov., *M. palauensis* sp. nov. and *M. borneensis* sp. nov. The genus *Babalimnichus* Satô, 1994 is treated as a junior synonym of the genus *Mexico* Spilman, 1972, and three known species of the genus *Babalimnichus* are transferred to *Mexico*, viz. *M. taiwanus* (Satô, 1994) comb. nov., *M. masamii* (Satô, 1994) comb. nov. and *M. splendens* (Hernando & Ribera, 2003) comb. nov. Additional specimen data are shown, and new distributional records are as follows: *Acontosceles chujoi* Yoshitomi & Satô, 2005 from Vietnam; *A. zetteli* Pütz, 2008 from Laos; *Pseudeucinetus javanicus* Yoshitomi & Putra, 2010 from Lombok Island; *Mexico taiwanus* (Satô, 1994) comb. nov. from Lutao, Lanhsu and the Yonaguni-jima Islands; and *M. masamii* (Satô, 1994) comb. nov. from Kume-jima. A species list of the subfamily Thaumastodinae is given, with ZooBank LSIIDs. The phylogenetic relationships of the thaumastodine genera are discussed.

**Keywords.** Coleoptera, Limnichidae, Thaumastodinae, new species, new synonym, identification key, checklist.

Yoshitomi H. 2019. Review of the Asian Thaumastodinae (Coleoptera, Byrrhoidea, Limnichidae), with a phylogeny of the genera. *European Journal of Taxonomy* 583: 1–45. <https://doi.org/10.5852/ejt.2019.583>

## Introduction

Limnichidae Erichson, 1846 (minute marsh-loving beetles), a ‘shore beetle’ family (Jäch 1998), includes both riparian and littoral species, and has about 400 known species in 37 genera (Hernando & Ribera 2005a). This family is subdivided into four subfamilies (Limnichinae Erichson, 1846; Hyphalinae Britton, 1971; Cephalobyrrhinae Champion, 1925; and Thaumastodinae Champion, 1924) and has not been well studied taxonomically. Furthermore, the phylogenetic position of the family and its subfamilies is still not understood (Hernando & Ribera 2005a). The phylogenetic placement of Limnichidae and its possible non-monophyly has been considered previously by many authors, both informally (e.g., Hinton 1939; Crowson 1978) and with cladistic analyses (e.g., Lawrence 1988; Beutel 1995). Costa *et al.* (1999) mentioned the phylogenetic position of the family and its subfamilies, but their relationships remained uncertain. The monophyly of the family Limnichidae was not supported, but the families Limnichidae, Dryopidae and Heteroceridae constitute a monophyletic clade. Kundrata *et al.* (2017) analysed the molecular phylogeny of Byrrhoidea and Buprestoidea, and three subfamilies (all except

Hyphalinae) of the family Limnichidae were treated. The family Limnichidae was a paraphyletic group due to Chelonariidae and Heteroceridae.

Thaumastodinae Champion, 1924 (so-called ‘jumping shore beetles’) is one of four subfamilies of the family Limnichidae and is represented by five genera from the Palearctic, Oriental, Australian and Neotropical Regions (see Appendix 1). The members of this subfamily have interesting morphological characters, e.g., capable of jumping using the hind legs, elongate body shape, and large eyes situated dorsally and separated narrowly on the vertex. In fact, Heller (1921) mistakenly stated that the genus *Pseudeucinetus* Heller, 1921, the first representative of this subfamily, was a member of the family Melandryidae Leach, 1815, and it was Champion (1924b) who recognized it as a member of Limnichidae. Zoogeographically, a disjunct distribution between the Oriental and Neotropical Regions (except for some species in the Palearctic and Australian Regions) is shown, but the reason for this distributional pattern is unclear (Hernando & Ribera 2005a). The Neotropical species have been relatively well studied (Spilman 1959, 1966; Wooldridge 1988; Skelley 2005), but the Oriental ones have not.

In this paper, I review the Asian genera and species of the subfamily Thaumastodinae and discuss the phylogenetic relationships of the genera.

## **Material and methods**

### **Taxonomy**

General observations and dissections were made using a Leica MZ95 stereo microscope. Microstructures of the dissected parts were studied in pure glycerine under an Olympus BH-2 compound microscope. After observation, the dissected parts were mounted on the same card as the specimen. Photographs were taken using a Leica MZ95 and combined in Helicon® Focus ver. 4.70.5 Pro (Helicon Soft® Limited). Some structures were observed with an SEM (Hitachi S-225), after coating with gold. Values in parentheses refer to the average.

### **Abbreviations for institutes**

- BPBM = Bishop Museum, Honolulu, Hawaii, USA  
EUMJ = Ehime University Museum, Matsuyama, Japan  
ITBC = BORNEENSIS Collection of the Institute for Tropical Biology & Conservation, Sabah University, Malaysia  
NME = Naturkundemuseum, Erfurt, Germany  
NMNS = National Museum of Natural Science, Taichung, Taiwan  
NMW = Naturhistorisches Museum, Vienna, Austria  
NSMT = National Science Museum, Tsukuba, Japan

### **Abbreviations for body measurements**

- EL = length of elytra at suture  
EW = maximum width of elytra  
HW = head width across eyes  
PL = mesal length of pronotum  
PW = maximum width of pronotum  
TL = total length (PL+EL)

### **Abbreviations for male genitalia measurements (Fig. 1)**

- BL = length of basal piece  
LL = length of lateral lobe  
ML = length of median lobe

### Phylogeny

For the phylogenetic analyses, I selected four genera from the subfamily as ingroups and one genus of the family Limnichidae as an outgroup:

Ingroups: *Acontosceles* Champion, 1924; *Pseudeucinetus* Heller, 1921; *Mexico* Spilman, 1972; and *Martinius* Spilman, 1959 (Thaumastodinae)

Outgroup: *Limnichus* Latreille, 1829 (Limnichinae)

Fourteen characters were selected for phylogenetic analysis (Appendix 2). Characters were coded as ‘0’, ‘1’ or ‘2’, and the data matrix is shown in Appendix 3. WinClada ver. 10.00.08 (Nixon 2002) and NONA ver. 2.0 (Goloboff 1999) were used for the analyses.

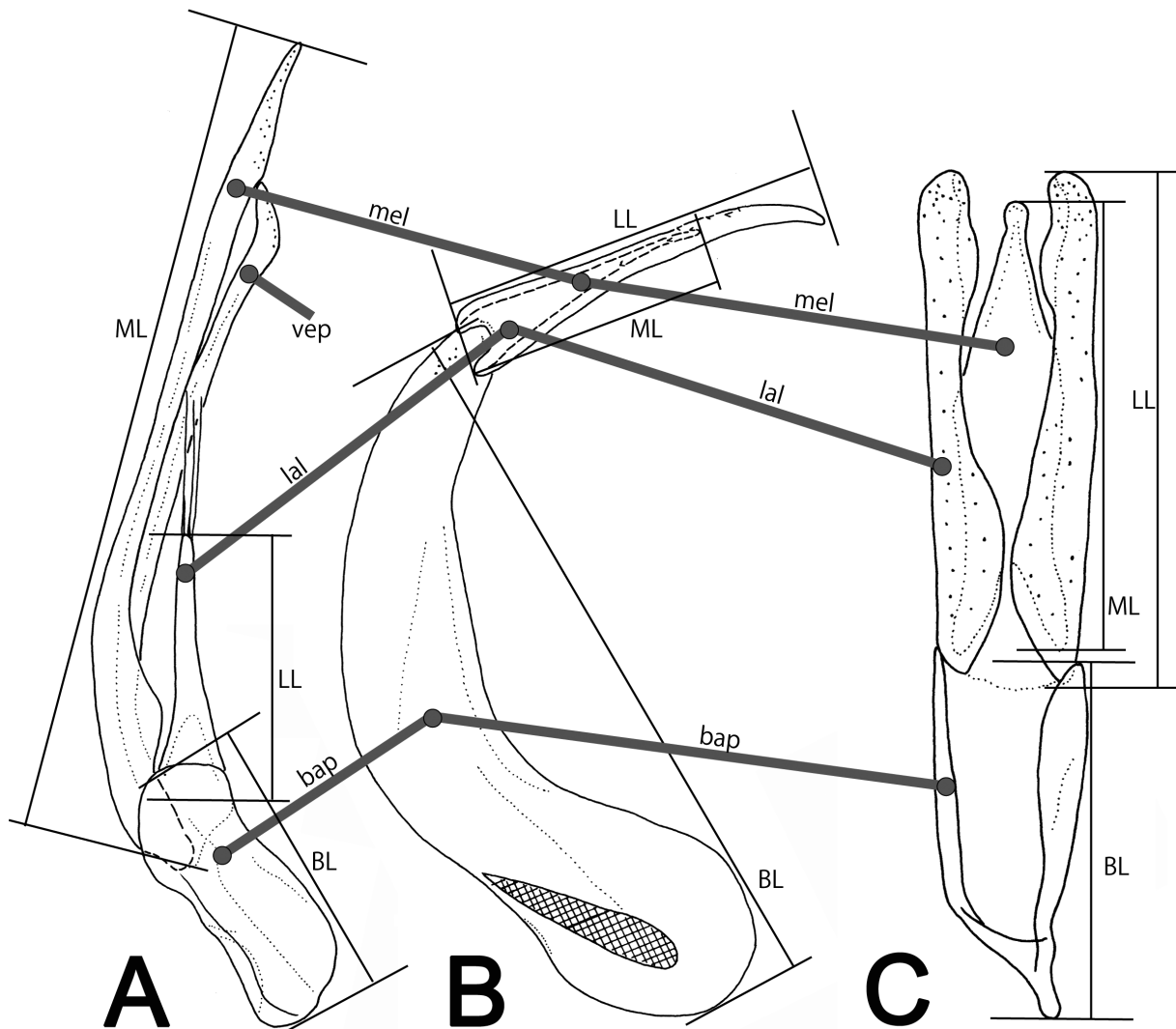

**Fig. 1.** Aedeagus, showing the terminology and the method of measurements. **A.** *Mexico* Spilman, 1972, left lateral view. **B.** *Acontosceles* Champion, 1924, left lateral view. **C.** *Pseudeucinetus* Heller, 1921, ventral view. Abbreviations: bap = basal piece; lal = lateral lobe; mel = median lobe; vep = ventral plate; BL = length of basal piece; LL = length of lateral lobe; ML = length of median lobe.

## Results

### *Taxonomic account*

Class Insecta Linnaeus, 1758  
Order Coleoptera Linnaeus, 1758  
Suborder Polyphaga Emery, 1886  
Series Elateriformia Crowson, 1960  
Superfamily Byrrhoidea Latreille, 1804  
Family Limnichidae Erichson, 1846

Subfamily **Thaumastodinae** Champion, 1924

Thaumastodinae Champion, 1924a: 25 (type genus: *Thaumastodus* Champion, 1924 [junior synonym of *Pseudeucinetus* Heller, 1921]).

Thaumastodinae – Spilman 1959: 111; 1972: 113 [key to genera]. — Skelley 2005: 119.

### Diagnosis

Body elongate to oblong, slightly shining, closely covered with short suberect setae. Eyes (Fig. 2) large, situated on dorso-lateral parts of head, separated narrowly on vertex. Antennae short to relatively short, 7- or 11-segmented, compactly articulated in terminal 6 antennomeres. Basal margin of elytra not crenulate. Tarsal formula 4-4-4 or 4-5-5. Hind legs long, capable of jumping; hind tibiae bearing spines. Sexual dimorphism distinct in fore tarsi (genus *Pseudeucinetus*) or in sternite VII.

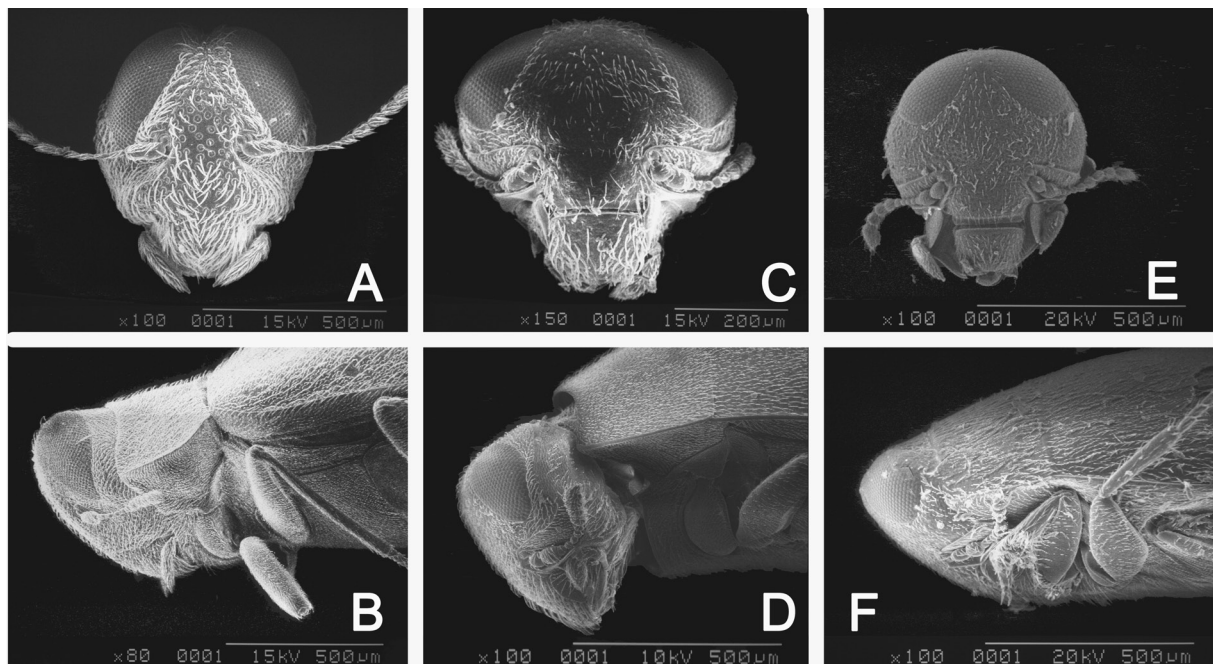

**Fig. 2.** Head in frontal (A, C, E) and lateral (B, D, F) views. **A, D.** *Acontosceles chujoi* Yoshitomi & Satô, 2005. **B, E.** *Mexico masamii* (Satô, 1994). **C, F.** *Pseudeucinetus zygops* Heller, 1921.

**Key to genera of the subfamily Thaumastodinae**

1. Tarsal formula 4-5-5; legs long and slender; antennal insertions situated near eyes (Fig. 2A); metaventrite short, not covering metacoxa (Fig. 3A); in freshwater environments; Oriental Region..... *Acontosceles* Champion, 1924
  - Tarsal formula 4-4-4; legs long and stout; antennal insertions situated near mandibles (Fig. 2C, E); metaventrite projecting posteriorly, covering metacoxa (Fig. 3B); in both fresh- and saltwater environments..... 2
2. Frons distinctly projecting anteriorly, narrow (Fig. 2E-F); male fore tarsi enlarged (Fig. 3E); in freshwater environments; Oriental Region..... *Pseudeucinetus* Heller, 1921
  - Frons gently projecting anteriorly, wide (Fig. 2C-D); male fore tarsi normal; on rocky seashores ... 3

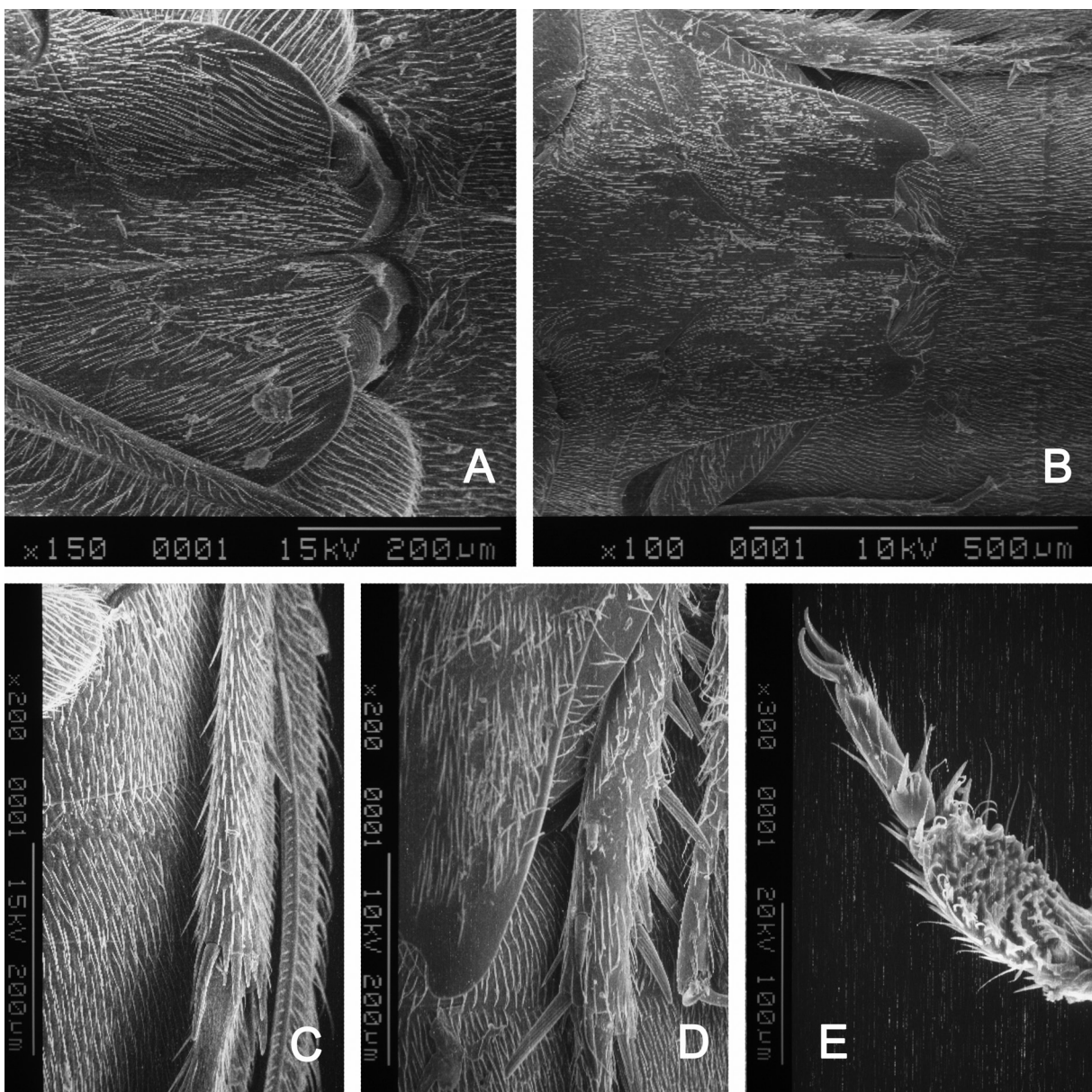

**Fig. 3.** Metacoxal plates (A–B), hind tibiae (C–D) and male protarsus (E). **A, C.** *Acontosceles chujoi* Yoshitomi & Satô, 2005. **B, D.** *Mexico taiwanus* (Satô, 1994). **E.** *Pseudeucinetus zygops* Heller, 1921.

3. Antennae 7-segmented; antennal groove on gena absent; Neotropical Region.....  
.....*Martinius* Spilman, 1959
- Antennae 11-segmented; antennal groove on gena present; Neotropical and Oriental Regions.....  
.....*Mexico* Spilman, 1972

Genus *Acontosceles* Champion, 1924

*Acontosceles* Champion, 1924a: 27 (type species: *Acontosceles hydroporoides* Champion, 1924).

**Diagnosis**

Body elongate. Gena wide; antennal groove absent. Antennae slender, relatively long, 11-segmented; antennal insertions situated near eyes. Legs long and slender; tarsal formula 4-5-5.

**Remarks**

This genus was subdivided into two species groups by Pütz (2008) mainly based on the male genital characters. However, the points differentiating the two groups are obvious and quantitative features (see also Yoshitomi & Putra 2011), and so the species-group concept needs to be revised.

**Biological notes**

The habitat of this genus (Fig. 4A) is freshwater environments, i.e., waterfalls (type locality of *A. chujoi* Yoshitomi & Satô, 2005), rivers and streams. The adults are found on wet rocks or actively flying. The larval stages are unknown.

**Key to the males of the species of *Acontosceles***

1. Basal piece distinctly curved ventrally, expanded in basal part; parameres long and curved ventrally, minutely serrate on dorso-lateral margins in some species; body shape elongate to oblong-oval; legs relatively long; Japan to India, Indonesia ..... 2 (*A. hydroporoides* species group)
- Basal piece slightly curved ventrally, not expanded in basal part; parameres short and almost straight, lacking serrae on dorso-lateral margins; body shape oblong-oval; legs relatively short; Indochina to Himalayas ..... 9 (*A. quatuordecimmaculosus* species group)
2. Aedeagus distinctly curved (about 90–100°) ventrally in basal piece ..... 5
- Aedeagus gently curved (about 120°) ventrally in basal piece ..... 3
3. Lateral lobes serrate on dorso-lateral margins ..... 4
- Lateral lobes lacking serrae on dorso-lateral margins ..... *A. hydroporoides* Champion, 1924
4. Basal piece slightly expanded in basal part; Indochina ..... *A. chujoi* Yoshitomi & Satô, 2005
- Basal piece robust, expanded in basal part; Japan and Taiwan ..... *A. yorioi* Satô, 1966
5. Lateral lobes serrate on dorso-lateral margins ..... 6
- Lateral lobes lacking serrae on dorso-lateral margins; Philippines ..... *A. negrosensis* Pütz, 2008
6. Basal piece robust, expanded in basal part ..... 7
- Basal piece slightly expanded in basal part; Borneo ..... *A. borneensis* sp. nov.
7. Basal piece curved in middle part ..... 8
- Basal piece curved in caudal part; Philippines ..... *A. jaechi* Pütz, 2008

8. Lateral lobes shorter; Indonesia..... *A. javanicus* Yoshitomi & Putra, 2011  
 – Lateral lobes longer; Philippines ..... *A. tagalog* Spilman, 1959
9. Apex of lateral lobes wide and truncate, with small denticles on lateral margins..... 10  
 – Apex of lateral lobes pointed, lacking denticles..... 11
10. Lateral margins of lateral lobes gently arcuate in dorsal view; Nepal..... *A. siwalikensis* Pütz, 2008  
 – Lateral margins of lateral lobes straight in dorsal view; Thailand and Laos..... *A. zetteli* Pütz, 2008
11. Basal piece relatively long; lateral lobes slightly curved in apical parts; Myanmar .....  
 ..... *A. quatuordecimmaculosus* Pütz, 2008  
 – Basal piece relatively short; lateral lobes curved ventrally in apical parts; China .....  
 ..... *A. yunnanensis* Pütz, 2008

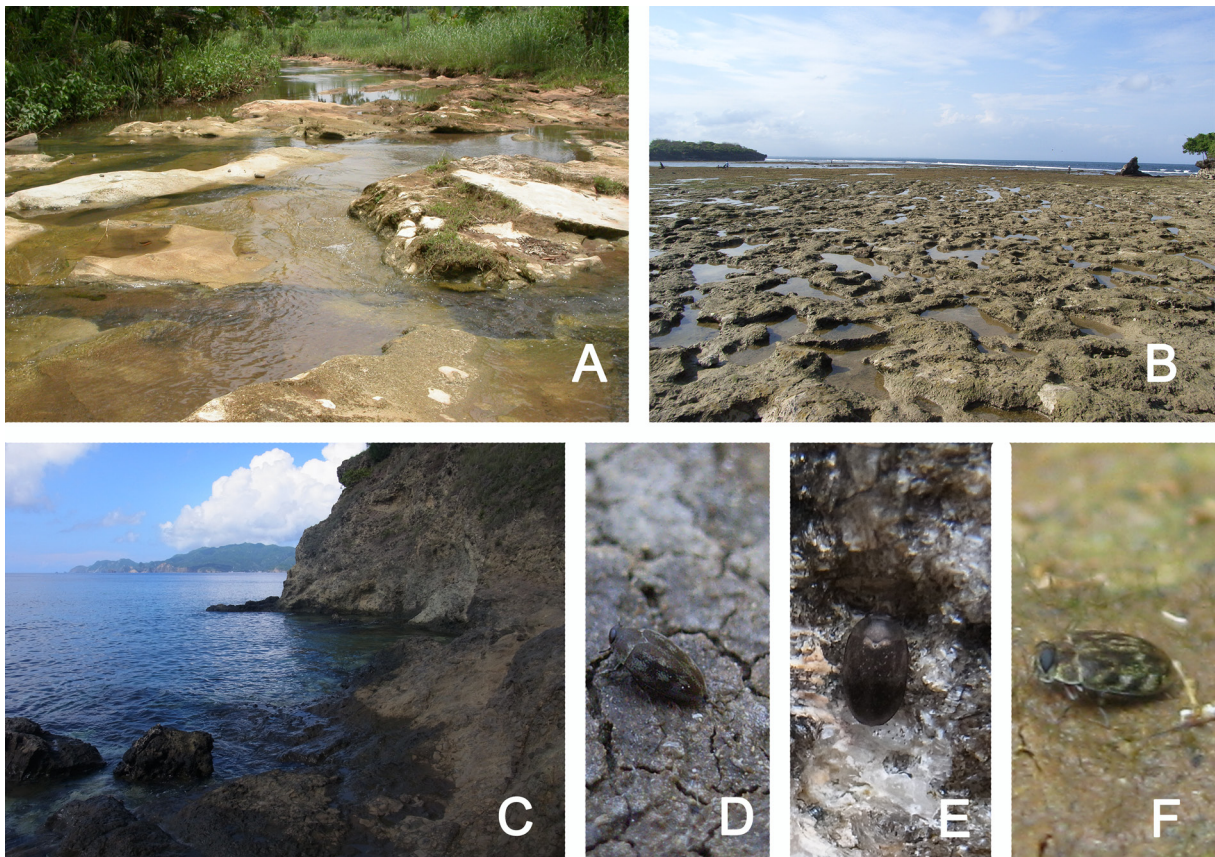

**Fig. 4.** Habitats (A–C) and living adults (D–F) of Asian Thaumastodinae Champion, 1924. **A.** Dondong River, Pengkol, Yogyakarta special Region, Java, Indonesia (type locality of *Acontosceles javanicus* Yoshitomi & Putra, 2011 (F) and *Pseudeucinetus javanicus* Yoshitomi & Putra, 2010 (D)). **B.** Nusa Dua, Bali, Indonesia (type locality of *Mexico baliensis* sp. nov.). **C.** Hirashima, Ogasawara, Japan (type locality of *Mexico ogasawaraensis* sp. nov.). **D.** Type locality of *Pseudeucinetus javanicus* Yoshitomi & Putra, 2010. **E.** *Mexico masamii* (Satô, 1994) in Shikinejima, Izu Islands. **F.** Type locality of *Acontosceles javanicus* Yoshitomi & Putra, 2011.

*Acontosceles borneensis* sp. nov.

[urn:lsid:zoobank.org:act:2582F411-8790-4937-B6A0-248899FD9208](https://zoobank.org/urn:lsid:zoobank.org:act:2582F411-8790-4937-B6A0-248899FD9208)

Figs 5A, 6

### Etymology

This species is named after its type locality.

### Material examined

#### Holotype

MALAYSIA • ♂; “SARAWAK: Nanga Pelagus 7-14. VIII. ‘58”; “T. C. Maa Collector BISHOP”; BPBM.

#### Paratypes

MALAYSIA • 1 ♂, 2 ♀♀; same collection data as for holotype; BPBM • 1 ♀; same collection data as for preceding; EUMJ • 2 ♀♀; “BORNEO: SARAWAK Merirai Valley nr Kapit, 30-300m, 1-6. VII. 58”; “T. C. Maa Collector BISHOP Mus.”; BPBM • 1 ♀; “BORNEO: SARAWAK Bau, Lake Area 29-30. VIII. 1958”; “T. C. Maa Collector BISHOP”; BPBM.

### Description

#### Male

**BODY.** Oblong, subparallel-sided, slightly convex dorsally, weakly shiny, closely covered with suberect silver setae. Coloration of body blackish brown, but mouthparts and legs yellowish brown; elytra with obscure silver spots consisting of erect setae.

**HEAD.** Moderate in size; frons and clypeus closely covered with erect, long silver setae; clypeus with straight anterior margin. Eyes large, prominent dorso-laterally.

**ANTENNAE.** Reaching about proximal half of pronotum.

**PRONOTUM.** Widest at basal third, densely bearing short yellowish setae and minute scale-like setae; PW/PL 2.25–2.50 (2.34). Scutellum small, subtriangular.

**ELYTRA.** Oblong, subparallel-sided near base to apical fifth, densely covered with short yellowish setae and minute scale-like setae, projecting ventrally in apical part; EL/EW 1.59–1.80 (1.72); EL/PL 4.17–4.63 (4.39); EW/PW 1.02–1.16 (1.10); TL/EW 1.97–2.22 (2.11).

**ABDOMEN.** Sternite VII (Fig. 6A) broad, gently arcuate along caudal margin, shallowly concave in median part, bearing about 20 long setae and three pairs of long and stout setae. Sternite VIII (Fig. 6B) membranous, bearing minute spines in apical parts. Sternite IX (Fig. 6C) moderately sclerotized, large, with small apical plates.

**AEDEAGUS** (Fig. 6D–E). Long, well sclerotized, strongly curved ventrally; basal piece oblong, expanded basally, evenly curved ventrally; lateral lobes long and slender, serrate on dorso-lateral margins, curved ventrally; median lobe long and slender, about 0.6 times as long as lateral lobe, gently curved ventrally; ML/BL 0.36; ML/LL 0.68.

#### Female

Sexual dimorphism distinct in the following characteristics: 1) frons and clypeus covered with short yellowish setae; 2) apical part of elytra projecting ventro-apically; 3) sternite VII (Fig. 6F) rather pointed on caudal margin, bearing about 40 long setae. Urosternite (Fig. 6G) well sclerotized, with long and



slender apodeme; lateral projections stout, bifid in apical parts. Ovipositor (Fig. 6H) well sclerotized; coxite sparsely punctuate, pointed at apices; approximate ratio of coxite and baculus ( $n = 1$ ) of 1.0 : 1.7.

#### Measurements

Unsexed ( $n = 4$ ): TL 2.17–2.25 (2.21) mm; PW 0.90–1.00 (0.96) mm; PL 0.40–0.42 (0.41) mm; EL 1.75–1.85 (1.80) mm; EW 1.00–1.10 (1.05) mm.

#### Distribution

Malaysia (Sarawak).

#### Remarks

This species belongs to the *hydroporoides* species group judging from characteristics of the male genitalia.

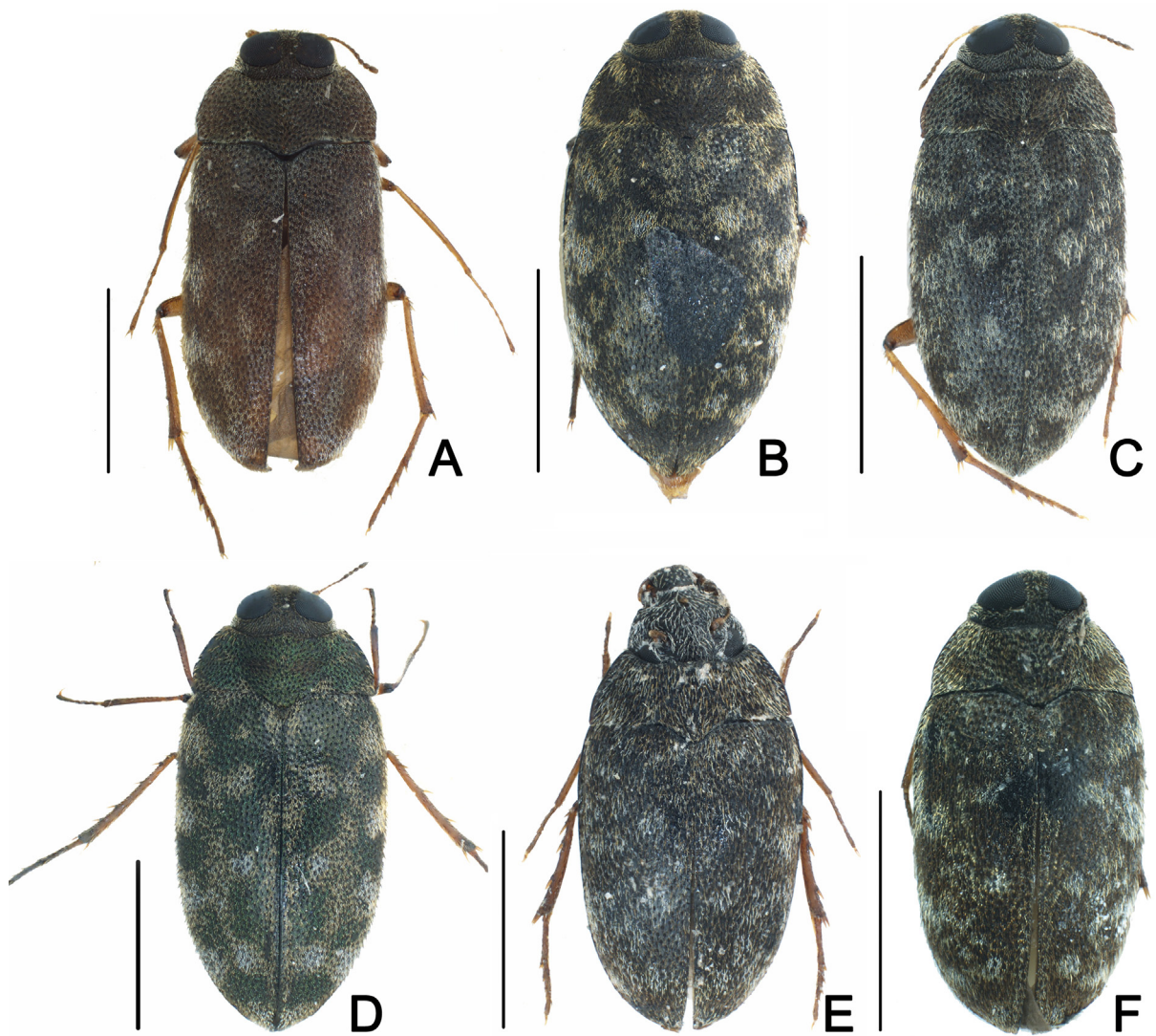

**Fig. 5.** *Acontosceles* spp. **A.** *A. borneensis* sp. nov., holotype (BPBM). **B.** *A. yorioi* Satô, 1966 (EUMJ). **C.** *A. hydroporoides* Champion, 1924 (NME). **D.** *A. chujoi* Yoshitomi & Satô, 2005 (EUMJ). **E.** *A. siwalikensis* Pütz, 2008 (NME). **F.** *A. zetteli* Pütz, 2008 (BPBM). Scale bars: 1.0 mm.

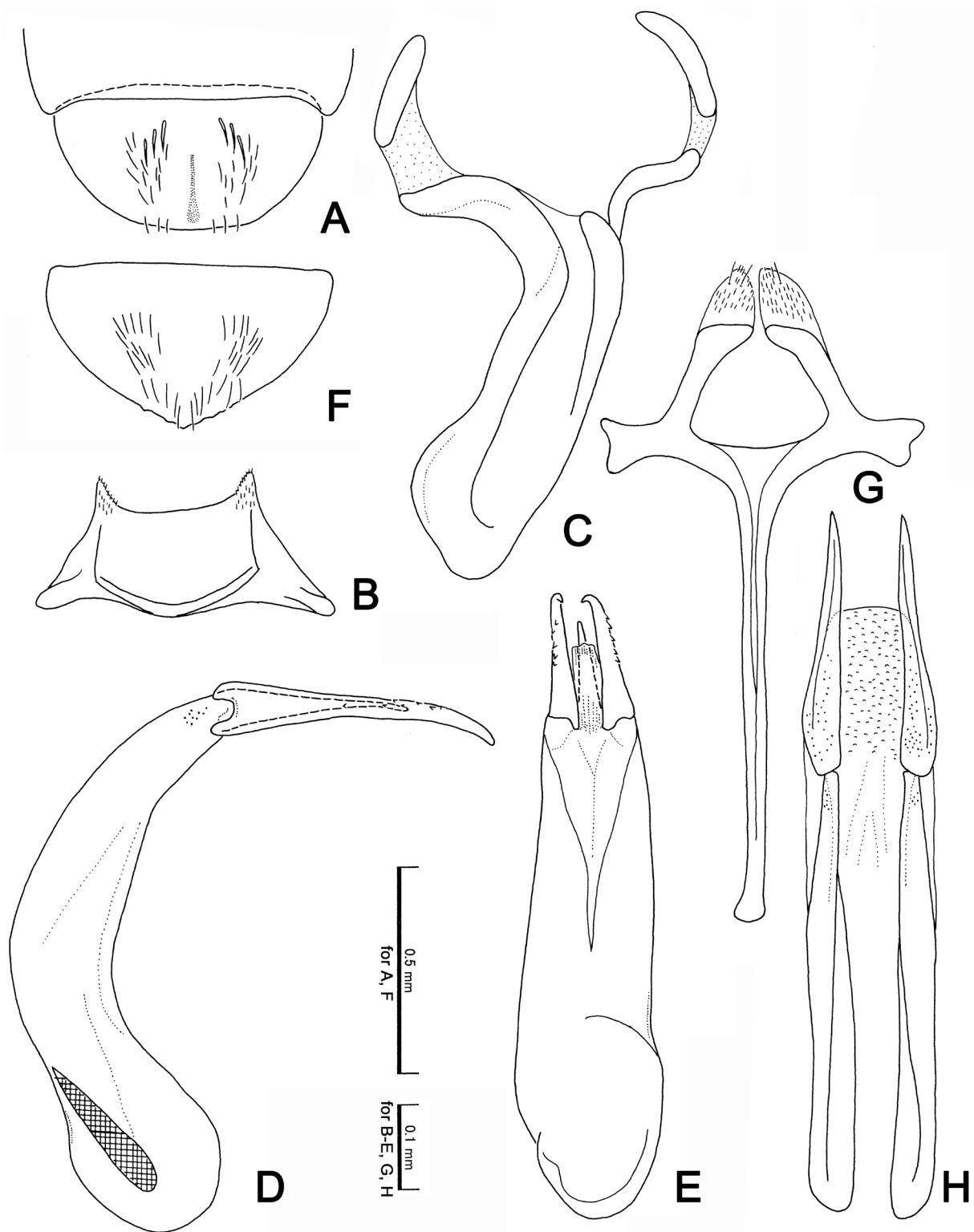

**Fig. 6.** *Acontosceles borneensis* sp. nov., male (A–E) and female (F–H) genitalia (holotype and paratype, BPBM). **A, F.** Sternite VII. **B.** Sternite VIII. **C.** Sternite IX. **D.** Aedeagus, left lateral view. **E.** Aedeagus, ventral view. **G.** Urosternite. **H.** Ovipositor.

*Acontosceles chujoi* Yoshitomi & Satô, 2005

Fig. 5D

*Acontosceles chujoi* Yoshitomi & Satô, 2005: 35.

**Material examined**

LAOS • 12 ex.; “[LA8] Nam Xan, near Ban Nahoung, Xieng Khouang Prov., Laos, 19°09.134" N, 103°43.037" E, 1453 m, 25. V. 2013 H. Yoshitomi leg.”; EUMJ • 23 ex.; “[LA23] 2km W of Nam Chat, Laos, 19°290137" N, 102°424900" E, ca 814 m, 22. IV. 2018, H. Yoshitomi leg.”; EUMJ.

VIETNAM • 5 ex.; “Tam Dao (950-1,050m) Vinh Phu Prov., Vietnam, 19. V. 1995 M. Sato leg.”; EUMJ • 11 ex.; “[VN6] Ban Khoang, Lao Cai Prov., Vietnam, N22 24.423 E103 47.309, ca 1284 m, 22. VI. 2012, H. Yoshitomi leg.”; EUMJ.

**Distribution**

Laos, Vietnam (new record).

*Acontosceles yorioi* Satô, 1966

Fig. 5B

*Acontosceles yorioi* Satô, 1966: 60.

*Acontosceles hydroporoides* – Satô 1965: 123 [misidentification]. — Spangler *et al.* 2001: 152 [Taiwan, error].

*Acontosceles yorioi* – Yoshitomi & Satô 2005: 36.

**Material examined**

JAPAN • 3 ex.; “Sate-gawa Kunigami, Okinawa 18-VI-2006 K. Takahashi leg.”; EUMJ • 3 ex.; “Hijikawa, Kunigami, Okinawa, Ryukyus 15-VI-2003 K. Takahashi leg.”; EUMJ.

TAIWAN • 1 ex.; “Taiwan Nantou Chunyang VI/11--VII/9/2002 C. S. Lin & W. T. Yang Malaise trap (KCN)”; “NMNS ENT 5240-73”; NMNS • 1 ex.; “Taiwan Nantou Chunyang V/7--VI/1/2002 C. S. Lin & W. T. Yang Malaise trap (KCN)”; “NMNS ENT 5237-3502”; NMNS • 1 ex.; “Taiwan Nantou Chunyang V/11-VII/3/2004 C. S. Lin & W. T. Yang Malaise trap (KCN)”; “NMNS ENT 5249-6740”; NMNS • 1 ex.; “Taiwan Pingtung Manchou Lite No: 169 Hsiang Rd. 3.8km IV/19--V/1/2009 M. L. Jeng & T. J. Chen Malaise trap”; NMNS.

**Distribution**

Japan: Ryukyu Islands (Okinawa-jima, Ishigaki-jima, Iriomote-jima); Taiwan.

*Acontosceles siwalikensis* Pütz, 2008

Figs 5E, 7

*Acontosceles siwalikensis* Pütz, 2008: 314.

**Material examined**

NEPAL • 1 ♂, 5 ex.; “NEPAL, Prov. Bheri Distr. Surkhet, 20km S Surkhet, Bheri-River 600m NN, 03. VI. 1995 leg. M. Hartmann”; NME • 1 ♂, 1 ♀; same collection data as for preceding; EUMJ.

### Redescription

For a detailed description of the external features, see the original description (Pütz 2008). PW/PL 2.63; EL/EW 1.58; EL/PL 4.70; EW/PW 1.13; TL/EW 1.92.

#### Male

Sternite VII (Fig. 7A) gently arcuate on caudal margin, bearing about 30 long setae in median part. Sternite VIII (Fig. 7B) membranous. Sternite IX (Fig. 7C) slightly sclerotized, with long apical plates bifid in apical parts. Aedeagus (Fig. 7D–F) relatively short, well sclerotized, slightly curved ventrally; basal piece oblong, subparallel-sided; lateral lobes short and broad, arcuate on lateral margins, closely punctuate, with small projections in lateral parts of apices; median lobe slender, about 0.8 times as long as lateral lobe, slightly curved ventrally; ML/BL 0.40; ML/LL 0.80.

#### Female

Sexual dimorphism slight. Sternite VII (Fig. 7G) arcuate on caudal margin, bearing about 40 long setae. Urosternite (Fig. 7H) well sclerotized, with long and slender apodeme; lateral projections short, projecting antero-laterally. Ovipositor (Fig. 7I) well sclerotized; coxite closely punctuate, pointed at apices; approximate ratio of coxite and baculus ( $n = 1$ ) 1.0:1.8.

### Measurements

Male ( $n = 1$ ): TL 2.28 mm; PW 1.05 mm; PL 0.40 mm; EL 1.88 mm; EW 1.19 mm.

### Distribution

Nepal.

*Acontosceles zetteli* Pütz, 2008  
Figs 5F, 8

*Acontosceles zetteli* Pütz, 2008: 317.

### Material examined

LAOS • 1 ♂; “LAOS: Vientiane Prov. Ban Van Eue 15. XII. 1966”; “Native Collector BISHOP”; BPBM.

### Redescription

#### Male

For a detailed description of the external features, see the original description (Pütz 2008). PW/PL 2.83; EL/EW 1.48; EL/PL 4.93; EW/PW 1.18; TL/EW 1.78.

Sternite VII (Fig. 8A) arcuate on caudal margin, bearing about 20 long setae in median part. Sternite VIII (Fig. 8B) membranous. Sternite IX (Fig. 8C) slightly sclerotized, with long apical plates bifid in apical parts. Aedeagus (Fig. 8D–F) short, well sclerotized, slightly curved ventrally; basal piece oblong, subparallel-sided; lateral lobes short and broad, straight on lateral margins, closely punctuate, minutely projecting ventro-laterally at apices; median lobe slender, about 0.8 times as long as lateral lobe, slightly curved ventrally; ML/BL 0.34; ML/LL 0.82.

#### Female

Unknown.

### Measurements

Male ( $n = 1$ ): TL 1.78 mm; PW 0.85 mm; PL 0.30 mm; EL 1.48 mm; EW 1.00 mm.

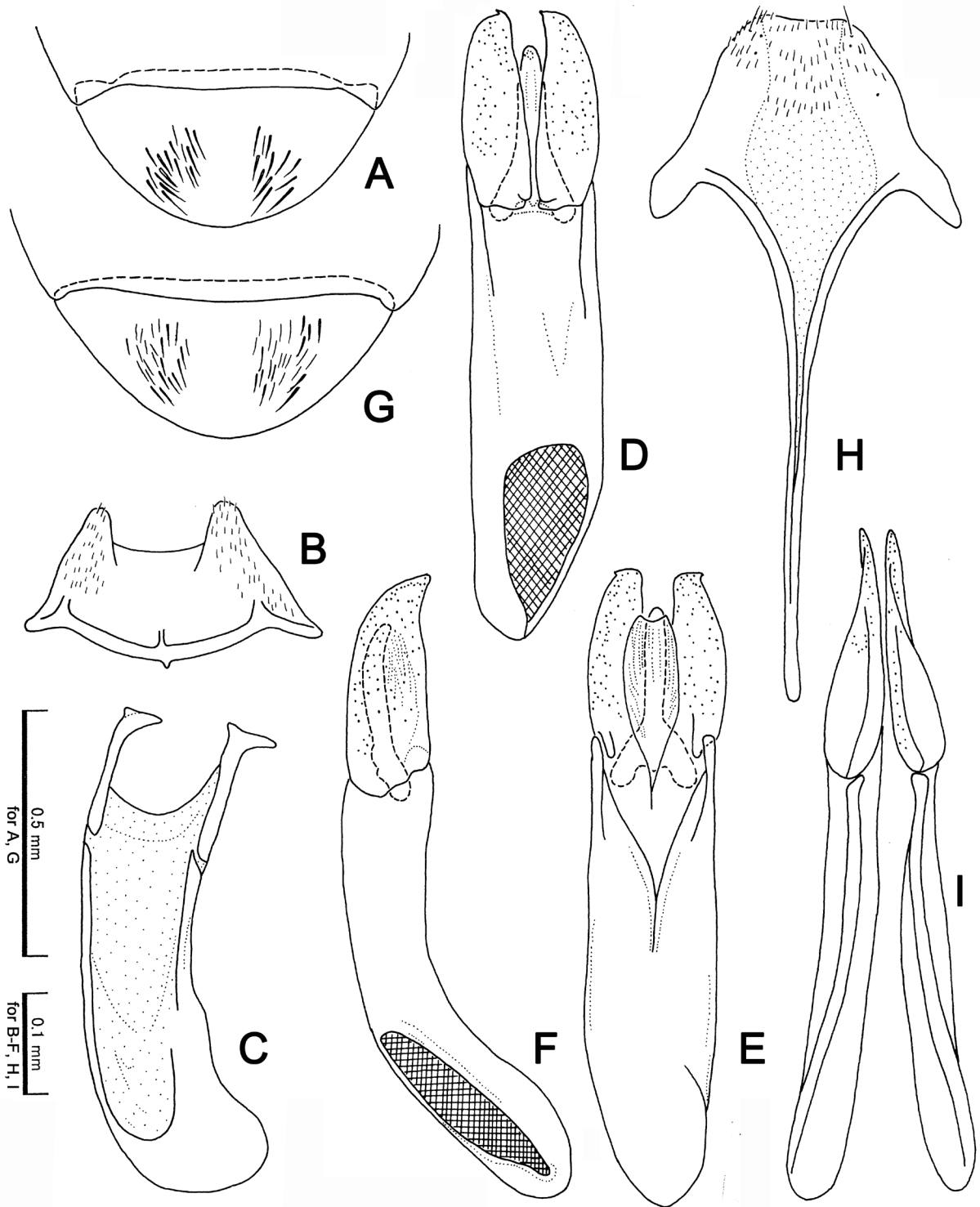

**Fig. 7.** *Acontosceles siwalikensis* Pütz, 2008, male (A–F) and female (G–I) genitalia (NME). **A**, **G**. Sternite VII. **B**. Sternite VIII. **C**. Sternite IX. **D**. Aedeagus, dorsal view. **E**. Aedeagus, ventral view. **F**. Aedeagus, left lateral view. **H**. Urosternite. **I**. Ovipositor.

## Distribution

Thailand, Laos (new record).

Genus *Pseudeucinetus* Heller, 1921

*Pseudeucinetus* Heller, 1921: 155 (type species: *Pseudeucinetus zygops* Heller, 1921).

*Thaumastodus* Champion, 1924a: 25 (type species: *Thaumastodus fusiformis* Champion, 1924; synonymized by Champion 1924b).

*Pseudeucinetus* – Satô 1994: 173. — Spangler 1995: 395.

## Diagnosis

Body oblong. Gena wide; shallow antennal groove present. Frons (Fig. 2E–F) narrow, distinctly projecting anteriorly. Antennae stout and short, 11-segmented; antennal insertions situated near mandibles. Legs relatively short and stout; tarsal formula 4-4-4; male fore tarsi enlarged (Fig. 3E).

## Remarks

This genus is easily distinguishable from other genera of the subfamily Thaumastodinae by the unique shape of the head: frons distinctly projecting anteriorly and narrow between the eyes.

## Biological notes

The habitat of this genus (Fig. 4A) is freshwater environments, i.e., rivers and streams. The adults are found in the splash zone of wet rocks, and frequently actively flying. In Java, Indonesia, *Pseudeucinetus*

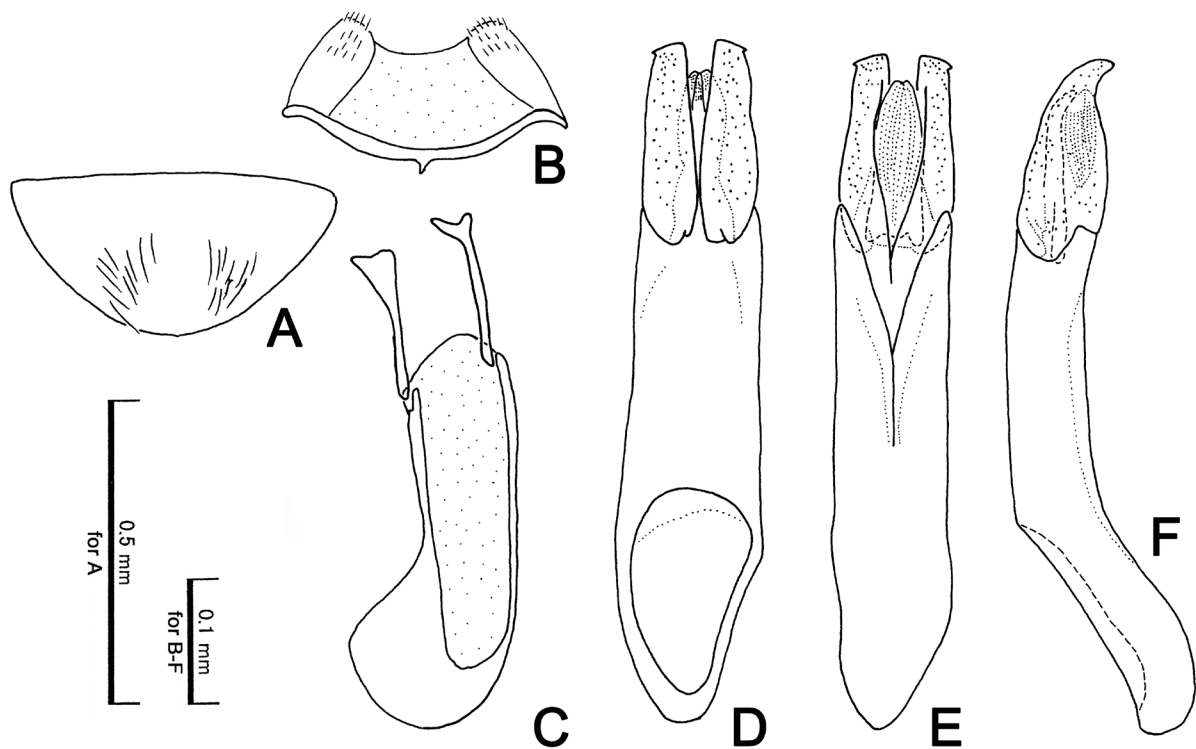

**Fig. 8.** *Acontosceles zetteli* Pütz, 2008, male genitalia (BPBM). **A.** Sternite VII. **B.** Sternite VIII. **C.** Sternite IX. **D.** Aedeagus, dorsal view. **E.** Aedeagus, ventral view. **F.** Aedeagus, left lateral view.

*javanicus* and *Acontosceles javanicus* were collected in the same place (Yoshitomi & Putra 2011). The adults were also collected by light trap. The larval stages are unknown.

**Key to the males of the species of *Pseudeucinetus*** (modified from Yoshitomi & Putra 2010)

1. Lateral lobes with a pair of small projections on inner margins..... 2
  - Lateral lobes without any projections on inner margin ..... 4
2. Subbasal inner projections of lateral lobes distinct and acute; basal piece short, about 0.5 times as long as lateral lobe ..... *P. novabritannica* Delève, 1973
  - Subbasal inner projections of lateral lobes absent; basal piece long, about 0.7–0.8 times as long as lateral lobe ..... 3
3. Subapical inner projections of lateral lobes small and obvious..... *P. papuanus* sp. nov.
  - Subapical inner projections of lateral lobes large and distinct .....  
..... *P. solomonicus* Yoshitomi & Putra, 2010
4. Apex of median lobe of aedeagus acuminate in dorsal or ventral view ..... 5
  - Apex of median lobe of aedeagus nipple-like in dorsal or ventral view .. *P. spilmani* Spangler, 1995
5. Median lobe strongly pointed at apex, straight on lateral margins; basal piece gently curved dorsally ..... *P. zygops* Heller, 1921
  - Median lobe weakly pointed at apex, arcuate on lateral margins; basal piece strongly curved dorsally ..... 6
6. Apices of lateral lobes straight, acute; median lobe widest at the middle ..... *P. uenoi* Spangler, 1995
  - Apices of lateral lobes obtuse; median lobe widest at basal part .....  
..... *P. javanicus* Yoshitomi & Putra, 2010

*Pseudeucinetus papuanus* sp. nov.

[urn:lsid:zoobank.org:act:978D5D6D-8D48-425D-AB1B-0536A2E10753](http://urn:lsid:zoobank.org:act:978D5D6D-8D48-425D-AB1B-0536A2E10753)

Figs 9A, 10

**Etymology**

This species is named after its type locality.

**Material examined**

**Holotype**

PAPUA NEW GUINEA • ♂; “NEW GUINEA NETH. Waris, S. of Hollandia, 450–500m VIII-I-2-1959”; “T. C. Maa Collector BISHOP”; “At Light”; BPBM.

**Description**

**Male**

**BODY.** Oval, slightly convex dorsally, shiny, closely covered with suberect silver setae. Coloration of body black; antennae and legs blackish brown.

**HEAD.** Moderate in size; clypeus with straight anterior margin. Eyes large; distance between eyes about 3 eye facets.

**ANTENNAE.** Short, reaching about anterior third of pronotum.

PRONOTUM. Widest at base; lateral margins straight; posterior margin gently bisinuate; PW/PL 2.33. Scutellum small, square.

ELYTRA. Oblong, widest at basal third; EL/EW 1.43; EL/PL 4.00; EW/PW 1.20; TL/EW 1.79. Fore tarsomere I largely expanded, longer than remaining fore tarsomeres combined.

ABDOMEN. Sternite VII (Fig. 10A) with three pairs of anterior extra setae (a) and two pairs of lateral extra setae (b). Sternite IX (Fig. 10B) moderately sclerotized, with long and pointed apical plates.

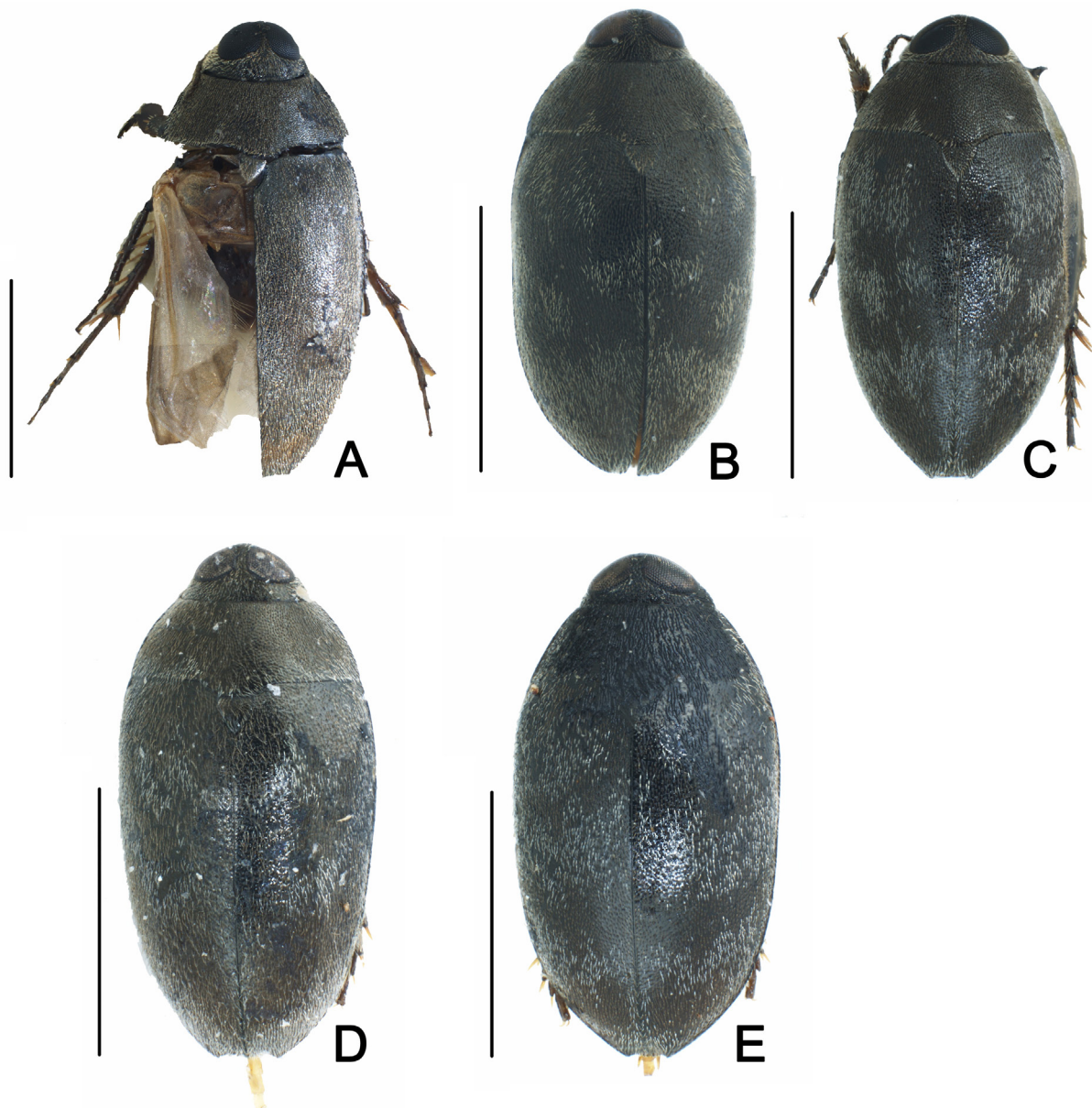

**Fig. 9.** *Pseudeucinetus* spp. **A.** *P. papuanus* sp. nov., holotype (BPBM). **B.** *P. uenoi* Spangler, 1995 (EUMJ). **C.** *P. javanicus* Yoshitomi & Putra, 2010, paratype (EUMJ). **D.** *P. solomonicus* Yoshitomi & Putra, 2010, paratype (EUMJ). **E.** *P. zygops* Heller, 1921 (EUMJ). Scale bars: 1.0 mm.



AEDEAGUS (Fig. 10C–D). Long, well sclerotized; basal piece oblong, subparallel-sided; lateral lobes long, about 1.4 times as long as basal piece, straight on lateral margins, with a pair of obtuse subapical inner projections on apical fifth; median lobe long, about 0.9 times as long as lateral lobes, nipple-like at apex; ML/BL 1.29; ML/LL 0.89.

**Female**

Unknown.

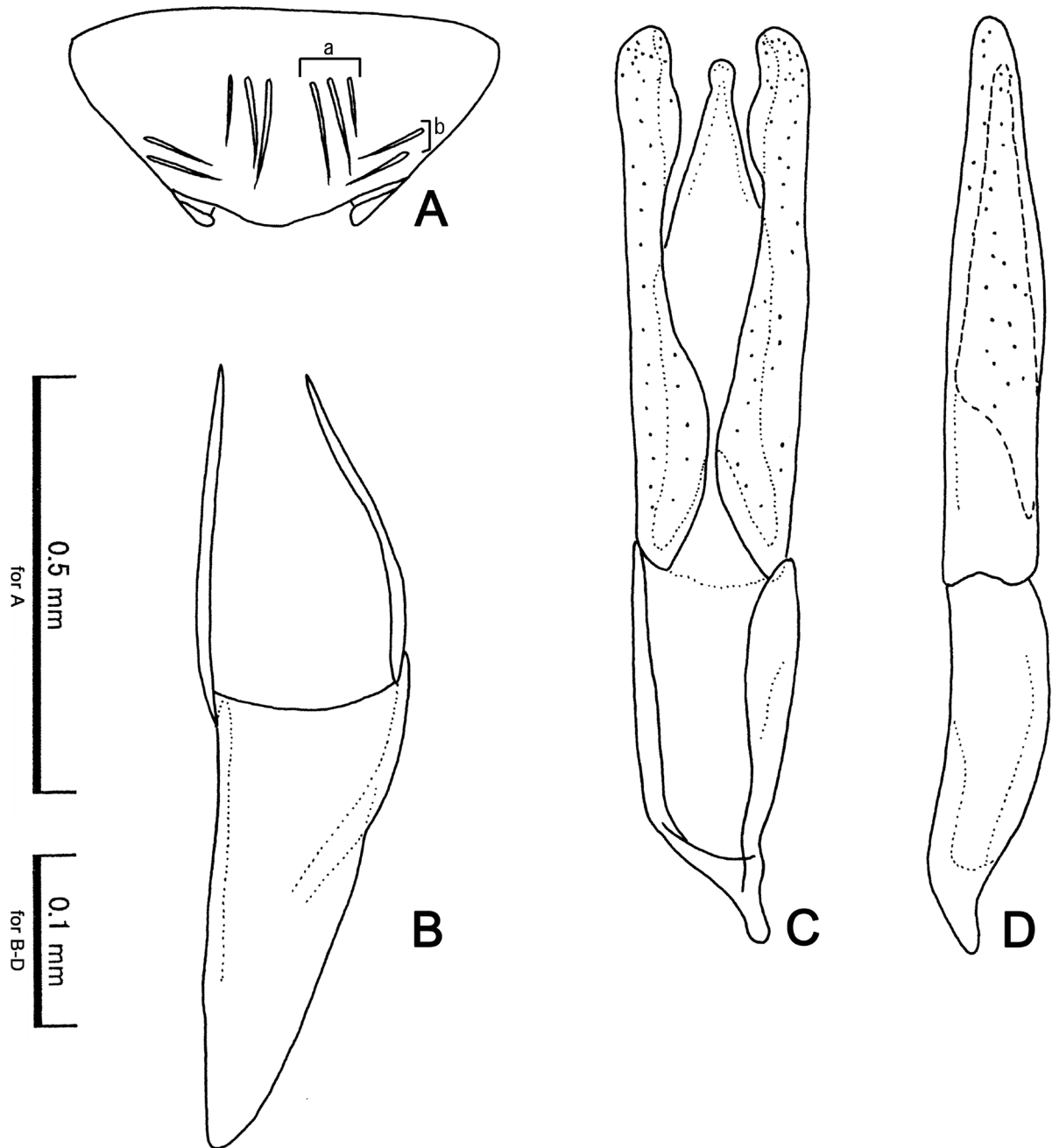

**Fig. 10.** *Pseudeucinetus papuanus* sp. nov., male genitalia, holotype, BPBM. **A.** Sternite VII. **B.** Sternite IX. **C.** Aedeagus, ventral view. **D.** Aedeagus, right lateral view.

### Measurements

Male (n = 1): TL 2.15 mm; PW 1.00 mm; PL 0.43 mm; EL 1.72 mm; EW 1.20 mm.

### Distribution

Papua New Guinea.

### Remarks

This species is related to *Pseudeucinetus novabritannica* from the Bismarck Archipelago and *P. solomonicus* from the Solomon Islands, and differs from them in the following characteristics: 1) subapical inner projection of lateral lobe obvious (large and distinct in *P. solomonicus*); 2) subbasal inner projection of lateral lobe absent (present in *P. novabritannica*); and 3) basal piece long, about 0.7 times as long as lateral lobe (about 0.5 in *P. novabritannica*, about 0.8 in *P. solomonicus*).

*Pseudeucinetus javanicus* Yoshitomi & Putra, 2010  
Figs 4A, D, 9C

*Pseudeucinetus javanicus* Yoshitomi & Putra, 2010: 144.

### Material examined

INDONESIA • 1 ♂; “INDONESIA: Lombok I: Aik Bukak 2. VII. 1978”; “J. T. Medler Coll. BISHOP Museum Acc. #1979. 483”; BPBM.

### Distribution

Indonesia (Java, Lombok).

### Remarks

This is the first record of this species from Lombok Island.

*Pseudeucinetus zygops* Heller, 1921  
Fig. 9E

*Pseudeucinetus zygops* Heller, 1921: 156.

*Thaumastodus fusiformis* Champion, 1924a: 27 (synonymized by Champion 1924b).

*Pseudeucinetus zygops* – Satô 1994: 173. — Spangler 1995: 401. — Yoshitomi 2004: 420.

### Material examined

INDONESIA • 1 ♂; “INDONESIA Southwest Sulawesi Aele 6–8. II. 2003 (LT) S. Hori leg.”; EUMJ.

MALAYSIA • 1 ♂; “MALAYA Selangor Connaught Bridge 14. III. 1958”; “T. C. Maa Collector BISHOP 108”; BPBM.

PHILIPPINES • 2 ♂♂, 2 ♀♀; “[PALAWAN] Olanguan (0m) 76km N. of Puerto Pron-cesa 31. VIII. 1985 M. Sakai leg.”; “attracted to mercury lamp”; EUMJ • 3 ♂♂; same collection data as for preceding but “26. VIII. 1985”; EUMJ • 1 ♀; “[PALAWAN] Trident Mine, 500m foot of Victoria Peak nr. Narra 4. IX. 1985 M. Sakai”; EUMJ • 1 ♂; same collection data as for preceding but “5. IX. 1985”; EUMJ • 1 ♂; “[PALAWAN] Olanguan (0–50m) between Puerto Princesa & Roxas 1. IX. 1985 M. Sakai”; EUMJ.

**Distribution**

India, Indonesia (Sulawesi), Malaysian Peninsula, Bismarck Archipelago (New Ireland), the Philippines (Balabac, Palawan, Mindanao, Negros).

*Pseudeucinetus uenoi* Spangler, 1995

Fig. 9B

*Pseudeucinetus uenoi* Spangler, 1995: 396.

**Material examined**

MALAYSIA • 1 ♂; “Miri Sarawak 11-XII-1968 M. Satô leg.”; EUMJ • 1 ♂; “MALAYSIA Mamut Ranau Sabah 27. II. 1995 [L. T.] YR. SAWADA leg.”; EUMJ • 1 ♂; “Malaysia SABAH Kg. Sukau, Sandakan 15-16. XII. 2009 H. Takizawa”; ITBC • 1 ♀; “Malaysia SABAH Kg. Tikolod, Salt trail Tambunan 11. XI. 2009 H. Takizawa”; ITBC • 1 ♀; “Malaysia SABAH Kg. Mansiang, Mengg-atal, Kota Kinabalu 21. XI. 2009 H. Takizawa”; ITBC.

**Distribution**

Malaysia (Sarawak, Sabah).

*Pseudeucinetus* sp.

**Material examined**

INDONESIA • 1 ♀; “IRIAN JAYA East of Serui Yapen Is. 28. VII. 1996 N. Ohbayashi”; EUMJ.

BRAZIL • 1 ♀; “BRAZIL: Cabo Frio 1m 20–21. XI. 1970”; “T. C. Maa Collector BISHOP”; BPBM.

**Remarks**

The single female specimen labelled as having been collected in Brazil is questionable, because this genus is otherwise known only from the Oriental Region.

Genus *Mexico* Spilman, 1972

*Mexico* Spilman, 1972: 113 (type species: *Mexico litoralis* Spilman, 1972, by original designation).

*Babalimnichus* Satô, 1994: 174 (type species: *Babalimnichus taiwanus* Satô, 1994: 174, by original designation). **Syn. nov.**

*Mexico* – Skelley 2005: 119.

*Babalimnichus* – Yoshitomi & Satô 2001: 472 [larval description].

**Diagnosis**

Body oblong. Gena relatively narrow; shallow antennal groove present. Antennae stout and short, 11-segmented; antennal insertions situated near mandibles. Legs relatively short and stout; tarsal formula 4-4-4.

**Remarks**

As already mentioned by Skelley (2005), *Babalimnichus* Satô, 1994 cannot be separated from *Mexico*, and it should be treated as a junior synonym of the latter.

The male genital structures are very peculiar, i.e., with very short lateral lobes with apical setae, longer median lobe and the presence of ventral plates (Fig. 1A).

### Biological notes

The habitat of this genus (Fig. 4B–C) is rocky seashores. The adults (Fig. 4E) are found in the splash zone of wet rocks, actively flying when disturbed. The larval stage was described by Yoshitomi & Satô (2001).

### Key to the males of the species of Asian *Mexico*\*

1. Lateral lobes long, exceeding proximal half of median lobe, with very short apical setae; Papua New Guinea..... *M. papuanus* sp. nov.  
– Lateral lobes short, reaching about proximal third of median lobe, with long apical setae ..... 2
2. Ventral plates almost of same proportion on right and left..... 4  
– Apical part of left ventral plates distinctly curved interiorly..... 3
3. Left ventral plates with thumb-like projection on inner margin of apex; median lobe rather slender; Taiwan and Japan, Yonaguni-jima ..... *M. taiwanus* Satô, 1994 comb. nov.  
– Left ventral plates long and curved interiorly in apical part, without thumb-like projection; median lobe wide, expanded in apical quarter; Japan, Honshu to Ishigaki-jima ..... *M. masamii* (Satô, 1994) comb. nov.
4. Apical part of ventral plates separated from median lobe; Palau ..... *M. palauensis* sp. nov.  
– Apical part of ventral plates connected with median lobe..... 5
5. Apex of median lobe nipple-like; Borneo ..... *M. borneensis* sp. nov.  
– Apex of median lobe simply pointed..... 6
6. Lateral lobe robust, with 2–3 apical setae; Bali..... *M. baliensis* sp. nov.  
– Lateral lobe slender, with 4 apical setae; Ogasawara Islands..... *M. ogasawaraensis* sp. nov.

\**Mexico splendens* (Hernando & Ribera, 2003) comb. nov. is omitted, because this species is only known from a female specimen.

### *Mexico ogasawaraensis* sp. nov.

[urn:lsid:zoobank.org:act:8B1989C3-5D1B-4E9C-A87F-0ED19524F6D4](https://zoobank.org/urn:lsid:zoobank.org:act:8B1989C3-5D1B-4E9C-A87F-0ED19524F6D4)

Figs 4C, 11C, 12

### Etymology

This species is named after its type locality.

### Material examined

#### Holotype

JAPAN • ♂; “[OG2] Meijima, Hahajima-guntô, Ogasawara Isls., Japan, 26°567418” N, 142°227674” E, 23. IX. 2012, H. Yoshitomi leg.”; EUMJ.

#### Paratypes

JAPAN • 4 ♂♂, 2 ex.; same collection data as for holotype; EUMJ • 1 ♂, 1 ♀; same collection data as for preceding; NSMT • 1 ♂, 1 ♀; same collection data as for preceding; NMW • 1 ♀; “[OG5] Minamizaki, Hahajima, Ogasawara Isls., Japan, 26°37.491” N, 142°10.600” E, 25. IX. 2012, H. Yoshitomi leg.”;

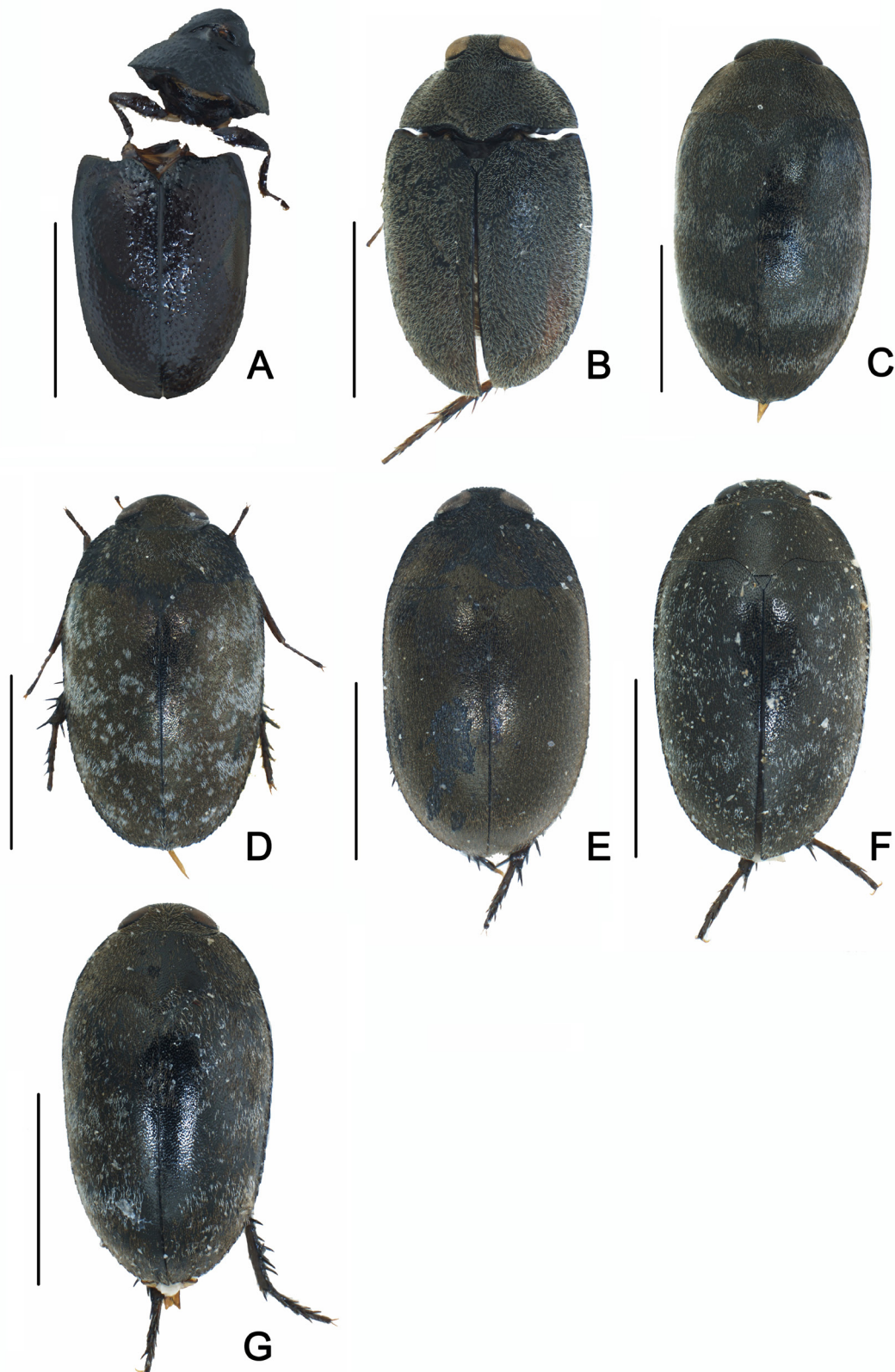

**Fig. 11.** Species of *Mexico* Spilman, 1972. **A.** *M. borneensis* sp. nov., holotype (BPBM). **B.** *M. papuanus* sp. nov., holotype (BPBM). **C.** *M. ogasawaraensis* sp. nov., holotype (EUMJ). **D.** *M. baliensis* sp. nov., holotype (EUMJ). **E.** *M. palauensis* sp. nov., holotype (EUMJ). **F.** *M. masamii* (Satô, 1994) (EUMJ). **G.** *M. taiwanus* (Satô, 1994), paratype (EUMJ). Scale bars: 1.0 mm.

EUMJ • 4 ♂♂, 2 ex.; “[OG4] Hirashima, Hahajima-guntô, Ogasawara Isls., Japan, 26°35.169” N, 142°09.177” E, 24. IX. 2012, H. Yoshitomi leg.”; EUMJ.

## Description

### Male

**BODY.** Oval, slightly convex dorsally, shiny, closely covered with suberect golden setae. Coloration of body black; elytra with indistinct and irregular silver spots consisting of erect setae.

**HEAD.** Closely and finely punctate, slightly convex between eyes; distance between eyes as long as an eye diameter in dorsal view.

**ANTENNAE.** Short, reaching about anterior third of pronotum.

**PRONOTUM.** Closely punctate, gently arcuate on lateral margins; PW/PL 1.92–2.30 (2.09). Scutellum equilateral triangular, punctate as in pronotum.

**ELYTRA.** Oval, widest at base, gently tapered posteriorly; caudal third of lateral margins slightly and indistinctly serrate; EL/EW 1.40–1.54 (1.48); EL/PL 3.25–4.00 (3.58); EW/PW 1.12–1.20 (1.16); TL/EW 1.80–1.96 (1.89).

**ABDOMEN.** Sternite VII (Fig. 12A) bearing about 40 long setae on mesal part, pointed at postero-lateral corners, slightly projecting on median part of caudal margin. Sternite VIII (Fig. 12B) slightly sclerotized, small, Y-shaped. Sternite IX (Fig. 12C) moderately sclerotized, relatively wide, strongly curved in basal part, with long and pointed apical plates.

**AEDEAGUS** (Fig. 12D–G). Long and slender, well sclerotized; basal piece oval; lateral lobes short and slender, with three apical setae; median lobe long and slender, slightly expanded in apical fifth, pointed at apex, finely punctate; ventral plates slender, reaching about apical fifth of median lobe, mostly fused to median lobe; ML/BL 2.94; ML/LL 2.42.

### Female

Sexual dimorphism slight. Sternite VII (Fig. 12H) bearing about 30 long setae on mesal part, pointed but minutely concaved at postero-lateral corners, slightly projecting on median part of caudal margin. Urosternite (Fig. 12I) well sclerotized, T-shaped, with long and slender apodeme. Ovipositor (Fig. 12J) well sclerotized; coxite sparsely punctate; apex of baculus bifid; approximate ratio of coxite and baculus (n = 1) 1.0:6.1.

## Measurements

Unsexed (n = 20): TL 2.10–2.65 (2.39) mm; PW 0.98–1.20 (1.09) mm; PL 0.45–0.60 (0.52) mm; EL 1.65–2.05 (1.86) mm; EW 1.10–1.40 (1.26) mm.

## Distribution

Japan: Ogasawara Islands (Hahajima, Meijima, Hirashima).

## Remarks

This species appears to be closely related to *M. baliensis* sp. nov. based on the shape of the aedeagus, but differs from it in the following characteristics: sternite IX broad (slender in *M. baliensis* sp. nov.), median lobe pointed at apex (somewhat obtuse in *M. baliensis* sp. nov.) and apical setae on lateral lobes long (short in *M. baliensis* sp. nov.).

**Biological notes**

The type series was collected from the splash zone of wet rocks on a rocky seashore (Fig. 4C).

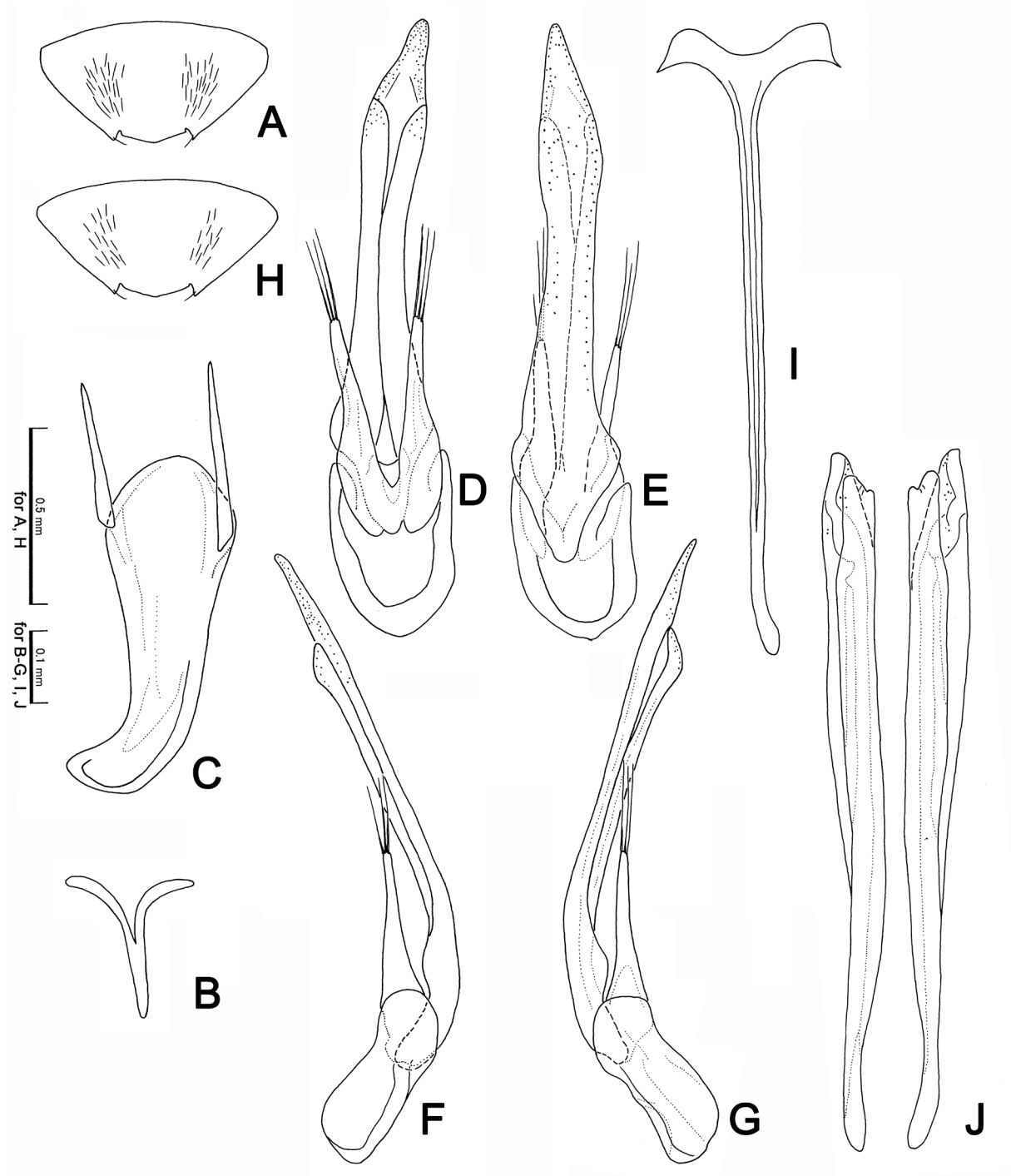

**Fig. 12.** *Mexico ogasawaraensis* sp. nov., male (A–G) and female (H–J) genitalia (paratypes, EUMJ). **A, H.** Sternite VII. **B.** Sternite VIII. **C.** Sternite IX. **D.** Aedeagus, ventral view. **E.** Aedeagus in dorsal view. **F.** Aedeagus in right lateral view. **G.** Aedeagus, left lateral view. **I.** Urosternite. **J.** Ovipositor.

*Mexico baliensis* sp. nov.

[urn:lsid:zoobank.org:act:98D64DE9-6A33-4EBF-A7F9-26F9A7BA409E](https://urn.lsid:zoobank.org:act:98D64DE9-6A33-4EBF-A7F9-26F9A7BA409E)

Figs 4B, 11D, 13

**Etymology**

This species is named after its type locality.

**Material examined**

**Holotype**

INDONESIA • ♂; “Bali Is. Indonesia Nusa Dua, Kuta South 16-II-2013 Kiyoshi ANDO leg.”; EUMJ.

**Paratypes**

INDONESIA • 1 ♂, 3 ♀♀, 2 ex.; same collection data as for holotype; EUMJ • 3 ex.; “Nusa Dua, North Island 8°47'52.72" S, 115°14'9.31" E, Bali, INDONESIA 7–8. VIII. 2010 H. Yoshitomi leg.”; EUMJ • 1 ex.; same collection data as for preceding; NMW • 1 ex.; same collection data as for preceding; BPBM • 4 ♂♂, 4 ♀♀, 13 ex.; “Nusa Dua, South Island 8°48'6.81" S, 115°14'16.07" E, Bali, INDONESIA 8. VIII. 2010 H. Yoshitomi leg.”; 1 ♀ on slide no HY 1141; EUMJ • 3 ex.; same collection data as for preceding; NMW • 3 ex.; same collection data as for preceding; BPBM.

**Description**

**Male**

**BODY.** Oval, slightly convex dorsally, shiny, closely covered with suberect golden setae. Coloration of body black; elytra with small, irregular silver spots consisting of erect setae.

**HEAD.** Finely punctate, projecting anteriorly between eyes; distance between eyes about 0.8 times as long as eye diameter in dorsal view.

**ANTENNAE.** Very short, reaching about anterior quarter of pronotum.

**PRONOTUM.** Closely punctate, gently arcuate on lateral margins; PW/PL 1.75–2.55 (2.06). Scutellum square.

**ELYTRA.** Oval, widest at base, gently tapered posteriorly; caudal third of lateral margins serrate; EL/EW 1.32–1.43 (1.38); EL/PL 2.53–4.00 (3.25); EW/PW 1.09–1.20 (1.14); TL/EW 1.67–1.88 (1.81).

**ABDOMEN.** Sternite VII (Fig. 13A) with two pairs (inner and outer) of long and stout setae and two extra pairs of such setae, pointed at postero-lateral corners, slightly projecting on median part of caudal margin. Sternite VIII (Fig. 13B) slightly sclerotized, small, Y-shaped. Sternite IX (Fig. 13C) moderately sclerotized, slender, curved in basal part; apical plates long, truncate at apices.

**AEDEAGUS** (Fig. 13D–G). Long and slender; basal piece oval, subparallel-sided; lateral lobes short and robust, with 2–3 apical setae; median lobe long and slender, subparallel-sided near base to apex, finely punctate, pointed at apex; ventral plates long and slender, reaching about apical tenth of median lobe, mostly fused to median lobe; ML/BL 2.26; ML/LL 2.72.

**Female**

Sexual dimorphism slight. Sternite VII (Fig. 13H) similar to that of male, but one pair, not two, of extra inner setae. Urosternite (Fig. 13I) well sclerotized, Y-shaped, with long and slender apodeme. Ovipositor (Fig. 13J) well sclerotized; coxite sparsely punctate, rather pointed at apices; apex of baculus bifid; approximate ratio of coxite and baculus (n = 1) 1.0:6.2.



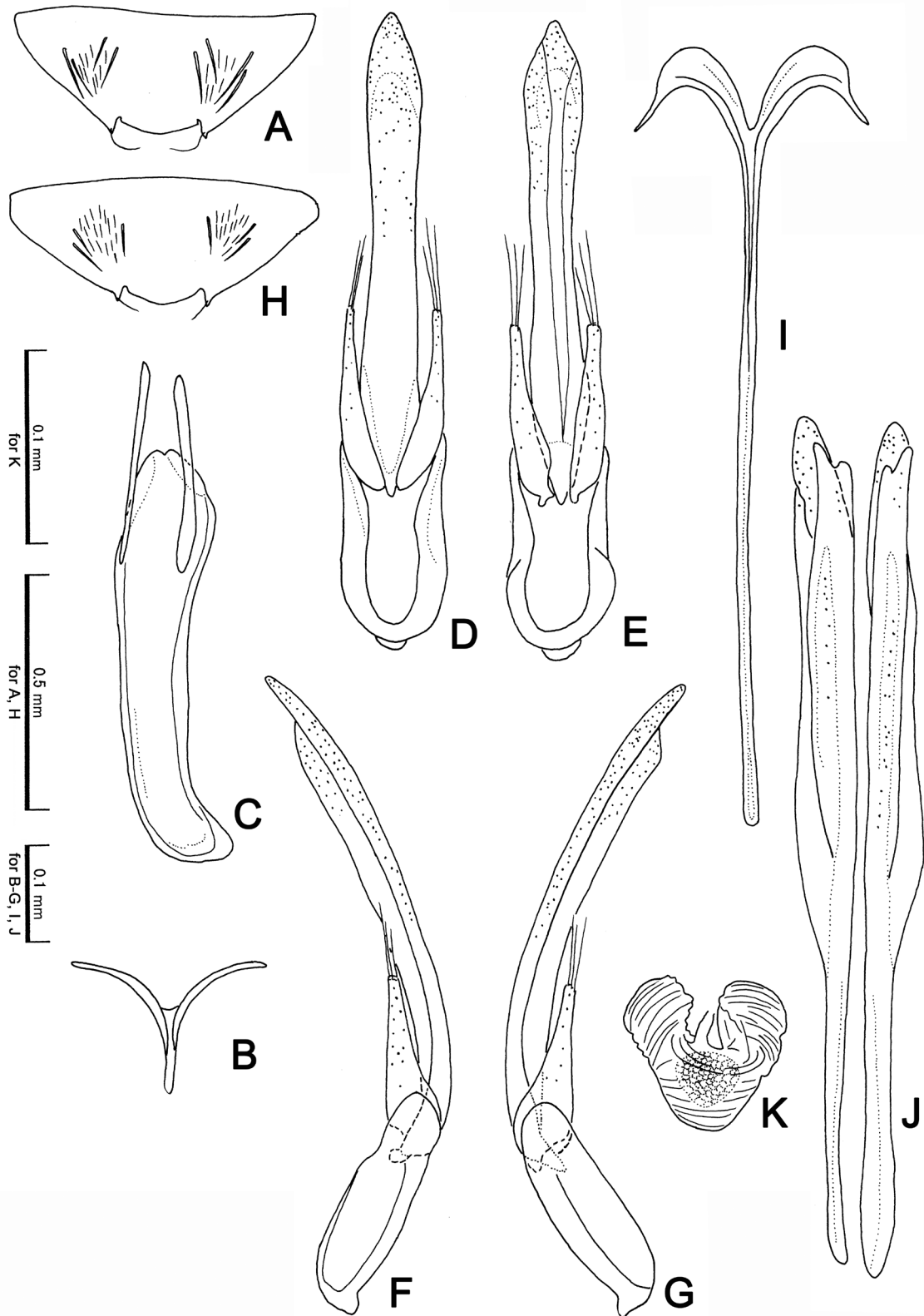

**Fig. 13.** *Mexico baliensis* sp. nov., male (A–G) and female (H–K) genitalia (paratypes, EUMJ). **A, H.** Sternite VII. **B.** Sternite VIII. **C.** Sternite IX. **D.** Aedeagus in dorsal view. **E.** Aedeagus, ventral view. **F.** Aedeagus in right lateral view. **G.** Aedeagus, left lateral view. **I.** Urosternite. **J.** Ovipositor. **K.** Spermatheca.

### Measurements

Unsexed (n = 20): TL 1.88–2.40 (2.19) mm; PW 0.95–1.13 (1.06) mm; PL 0.40–0.60 (0.52) mm; EL 1.48–1.80 (1.67) mm; EW 1.05–1.30 (1.21) mm.

### Distribution

Indonesia (Bali Island).

### Remarks

This species is similar to *M. borneensis* sp. nov. in the shape of the aedeagus, but differs from it in the following characteristics: median lobe obtuse at apex (pointed in *M. borneensis* sp. nov.); and apical setae on lateral lobes relatively short (long in *M. borneensis* sp. nov.).

### Biological notes

The type series was collected from the surface of wet rocks on a seashore (Fig. 4B) together with three species of *Laius* Guérin-Méneville, 1830 (Melyridae: *L. baliensis* Yoshitomi, 2014, *L. satoi* Yoshitomi, 2008 and *L. pankowi* Wittmer, 1999) and *Parathroscinus* sp. (Limnichidae) (Yoshitomi 2008, 2014b).

*Mexico papuanus* sp. nov.

[urn:lsid:zoobank.org:act:DB69DE47-18E6-4FA0-8D94-A9A95470D78E](https://zoobank.org/urn:lsid:zoobank.org:act:DB69DE47-18E6-4FA0-8D94-A9A95470D78E)

Figs 11B, 14

### Etymology

This species is named after its type locality.

### Material examined

#### Holotype

PAPUA NEW GUINEA • ♂; “NEW GUINEA (NE) Dreikikir, Sepik Distr., 350m 25. VI. 1961”; “J. L. & M. Gressitt Collectors”; BPBM.

#### Paratypes

PAPUA NEW GUINEA • 1 ♂, 1 ♀; same collection data as for holotype; BPBM • 1 ♀; same collection data as for holotype but “23. VI. 1961”; BPBM • 1 ♀; same collection data as for holotype but “24. VI. 1961”; BPBM • 1 ♀; “NEW GUINEA: NETH. VOG ELKOP: Bomberi 700–900m, VI-9-‘59”; “J. L. Gressitt Collector”; BPBM • 1 ♂; “NE New Guinea Morabe Distr. 10km W Bulolo 780m, 5–25. VIII, 1967”; “Malaise tr. over stream”; “R. Straatman Collector BISHOP MUS.”; BPBM • 1 ♂; “NE NEW GUINEA Akivitana Riv. 1550m, 10. I. 65”; “J. & M. Sedlacek Collectors BISHOP MUSEUM”; BPBM • 1 ♂; “NEW GUINEA: NETH. Waris, S. of Hollandia, 450–500m VIII-1-2-1959”; “At Light”; “T. C. Maa Collector BISHOP”; BPBM.

### Description

#### Male

**BODY.** Oval, relatively flat dorsally, shiny, closely covered with suberect golden setae. Coloration of body black; antennae and legs dark brown; elytra with indistinct and irregular silver spots consisting of erect setae.

**HEAD.** Finely punctate, shallowly depressed on dorsum between eyes; distance between eyes as long as eye diameter in dorsal view.

ANTENNAE. Slender and short, reaching about anterior third of pronotum.

PRONOTUM. Closely and rugosely punctate, with lateral margins almost straight; PW/PL 2.51–2.71 (2.61). Scutellum small, square.

ELYTRA. Oval, widest at base, gently tapered posteriorly; caudal quarter of lateral margins slightly and minutely serrate; EL/EW 1.35–1.40 (1.38); EL/PL 3.77–4.00 (3.88); EW/PW 1.05–1.11 (1.08); TL/EW 1.71–1.75 (1.73).

ABDOMEN. Sternite VII (Fig. 14A) with two (inner and outer) pairs of long and slender setae and two extra setae, pointed in postero-lateral corners, gently projecting triangularly on mesal part of caudal margin. Sternite VIII (Fig. 14B) small, slightly sclerotized, Y-shaped. Sternite IX (Fig. 14C) wide, gently curved in basal part; apical plates long and slender, pointed at apices.

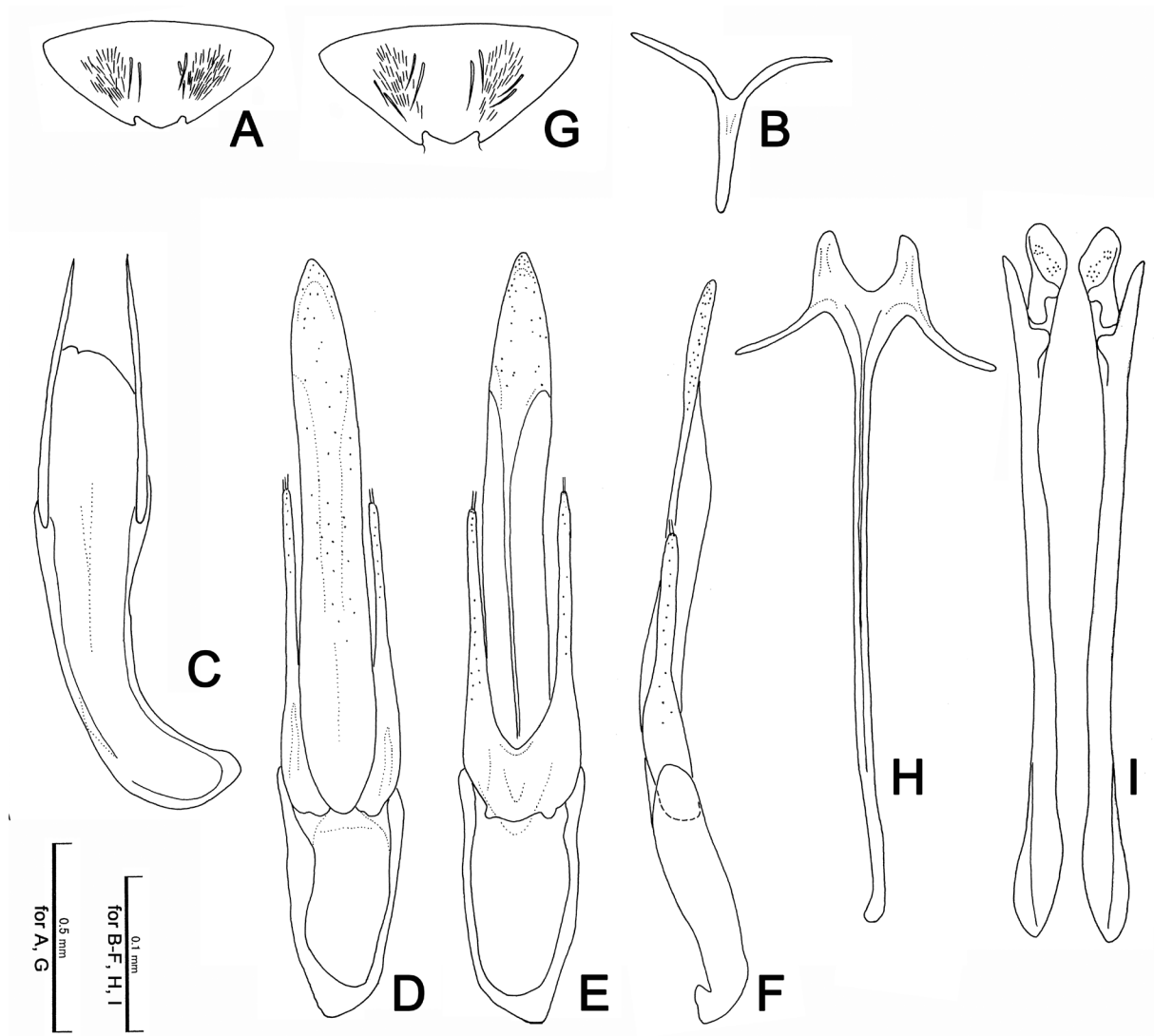

**Fig. 14.** *Mexico papuanus* sp. nov., male (A–F) and female (G–I) genitalia (holotype and paratype, BPBM). **A, G.** Sternite VII. **B.** Sternite VIII. **C.** Sternite IX. **D.** Aedeagus in dorsal view. **E.** Aedeagus, ventral view. **F.** Aedeagus, left lateral view. **H.** Urosternite. **I.** Ovipositor.

**AEDEAGUS** (Fig. 14D–F). Long, almost symmetrical; basal piece oval; lateral lobes short, with 4 short apical setae; median lobe slender, sparsely punctuate in apical part, slightly expanded in apical quarters, pointed and somewhat prolonged at apex; ventral plates slender, expanded apically, separated to median lobe; ML/BL 2.35; ML/LL 2.61.

#### **Female**

Sexual dimorphism slight. PW/PL 2.38–2.45 (2.42); EL/EW 1.36–1.42 (1.40); EL/PL 3.70–4.11 (3.85); EW/PW 1.07–1.18 (1.14); TL/EW 1.73–1.79 (1.76). Sternite VII (Fig. 14G) similar to that of male, but postero-lateral corners shallowly concave at apices. Urosternite (Fig. 14H) well sclerotized, Y-shaped, with long and slender apodeme. Ovipositor (Fig. 14I) well sclerotized; coxite sparsely punctuate, rather pointed at apices; apex of baculus bifid; approximate ratio of coxite and baculus ( $n = 1$ ) 1.0 : 5.6.

#### **Measurements**

Male ( $n = 2$ ): TL 1.75–2.05 (1.90) mm; PW 0.95–1.08 (1.02) mm; PL 0.35–0.43 (0.39) mm; EL 1.40–1.62 (1.51) mm; EW 1.00–1.20 (1.10) mm. Female ( $n = 3$ ): TL 1.88–2.30 (2.03) mm; PW 0.95–1.10 (1.01) mm; PL 0.40–0.45 (0.42) mm; EL 1.48–1.85 (1.61) mm; EW 1.05–1.30 (1.15) mm.

#### **Distribution**

Papua New Guinea.

#### **Remarks**

This species is distinct in the peculiar form of the male genitalia.

*Mexico palauensis* sp. nov.

[urn:lsid:zoobank.org:act:9A734C2D-BF7A-4F05-8628-36655720A091](https://zoobank.org/act:9A734C2D-BF7A-4F05-8628-36655720A091)

Figs 11E, 15

#### **Etymology**

This species is named after its type locality.

#### **Material examined**

##### **Holotype**

PALAU • ♂; “Carp Is. Palau 13–15. IX. 2002 M. Sato leg.”; EUMJ.

##### **Paratypes**

PALAU • 49 ex.; same collection data as for holotype; EUMJ • 4 ex.; same collection data as for preceding; NMW • 4 ex.; same collection data as for preceding; BPBM • 1 ♀, 2 ex.; “Carp Is. Palau 20-VII-2003 K. Takahashi leg.”; EUMJ • 1 ♂, 4 ex.; “Palau Angaur Is. 16-VIII-2003, M. Sato leg.”; EUMJ • 1 ♂, 6 ex.; “Palau Peleliu Is. 13–17. VIII. 2003 M. Sato leg.”; 1 ♂ on slide no. HY 1038; EUMJ.

#### **Description**

##### **Male**

**BODY.** Oval, slightly convex dorsally, shiny, closely covered with suberect golden setae. Coloration of body black; elytral silver spots indistinct.

**HEAD.** Finely punctate, slightly convex on dorsum between eyes; distance between eyes about 0.8 times as long as eye diameter in dorsal view.

**ANTENNAE.** Very short, reaching about anterior quarter of pronotum.

PRONOTUM. Closely punctate, gently arcuate on lateral margins; PW/PL 1.96–2.80 (2.22). Scutellum small, square.

ELYTRA. Oval, widest at base, gently tapered posteriorly; caudal third of lateral margins slightly and indistinctly serrate; EL/EW 0.42–1.43 (1.30); EL/PL 1.13–4.13 (3.14); EW/PW 1.05–1.16 (1.09); TL/EW 0.79–1.87 (1.72).

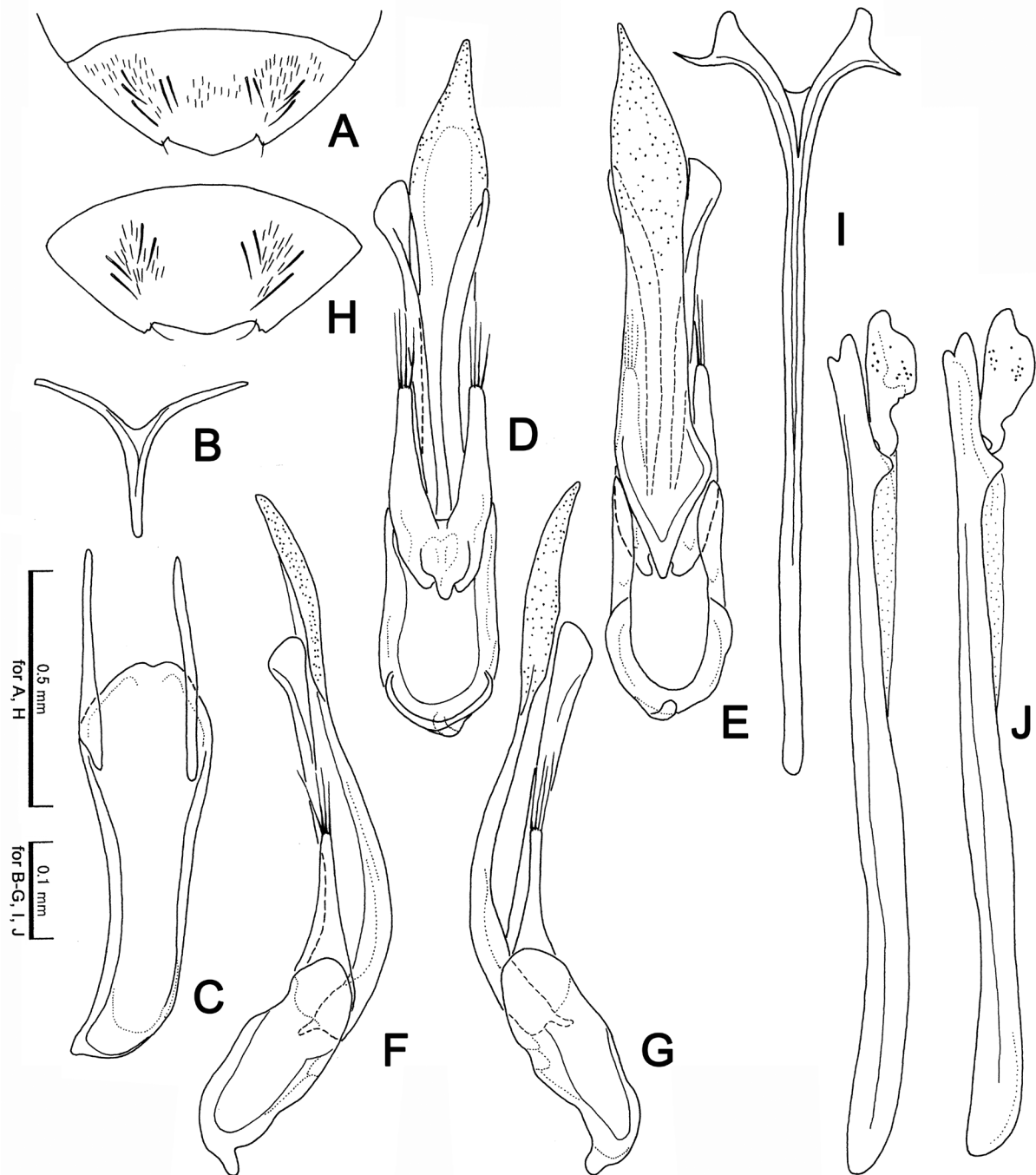

**Fig. 15.** *Mexico palauensis* sp. nov., male (A–G) and female (H–J) genitalia (paratypes, EUMJ). **A, H.** Sternite VII. **B.** Sternite VIII. **C.** Sternite IX. **D.** Aedeagus, ventral view. **E.** Aedeagus in dorsal view. **F.** Aedeagus in right lateral view. **G.** Aedeagus, left lateral view. **I.** Urosternite. **J.** Ovipositor.

ABDOMEN. Sternite VII (Fig. 15A) with two pairs of long and stout extra setae, bearing about 50 long setae, obtuse at postero-lateral corners, pentagonally projecting in median part of caudal margin. Sternite VIII (Fig. 15B) slightly sclerotized, small, Y-shaped. Sternite IX (Fig. 15C) well sclerotized, curved in basal part; apical plates long, pointed at apices.

AEDEAGUS (Fig. 15D–G). Long and slender, almost symmetrical; basal piece oval, gently tapering basally; lateral lobes relatively long and slender, with 2–3 very short apical setae, sparsely punctuate; median lobe long, subparallel-sided near base to apical fifth, sparsely punctuate, pointed at apex; ventral plates long and slender, reaching about apical fifth of median lobe, mostly fused to median lobe; ML/BL 2.06; ML/LL 1.92.

### Female

Sexual dimorphism slight. Sternite VII (Fig. 15H) similar to that of male. Urosternite (Fig. 15I) well sclerotized, with long and slender apodeme, with slender lateral projections. Ovipositor (Fig. 15J) well sclerotized; coxite punctuate, obtuse at apices; apex of baculus pointed; approximate ratio of coxite and baculus ( $n = 1$ ) 1.0:6.8.

### Measurements

Unsexed ( $n = 20$ ): TL 0.85–2.23 (1.93) mm; PW 0.82–1.12 (1.03) mm; PL 0.35–0.55 (0.47) mm; EL 0.45–1.68 (1.46) mm; EW 0.95–1.20 (1.12) mm.

### Distribution

Palau (Carp, Peleliu Islands).

### Remarks

This species is similar to *M. borneensis* sp. nov. in the shape of the aedeagus, but differs from it in the following characteristics: ventral plates separated from median lobe (attached in *M. borneensis* sp. nov.) and apical setae on lateral lobes short (long in *M. borneensis* sp. nov.).

*Mexico borneensis* sp. nov.

[urn:lsid:zoobank.org:act:C119FDE3-9A59-4A07-A77A-AF4C067C5D1B](https://zoobank.org/act:C119FDE3-9A59-4A07-A77A-AF4C067C5D1B)

Figs 11A, 16

### Etymology

This species is named after its type locality.

### Material examined

#### Holotype

MALAYSIA • ♂; “BRITISH N BORNEO Labuan Island Nov. 28–29, 1958”; “Intertidal Zone”; “L. W. Quate Collector”; BPBM.

#### Paratypes

MALAYSIA • 1 ♀; same collection data as for holotype; BPBM • 1 ♂, 1 ex.; “BRITISH N BORNEO Labuan Island Nov. 28–29, 1959”; “Intertidal Zone”; “Maa Collector”; BPBM.

### Description

#### Male

BODY. Oval, slightly convex dorsally, shiny, closely covered with suberect golden setae. Coloration of body black; elytra with small, irregular silver spots consisting of erect setae.

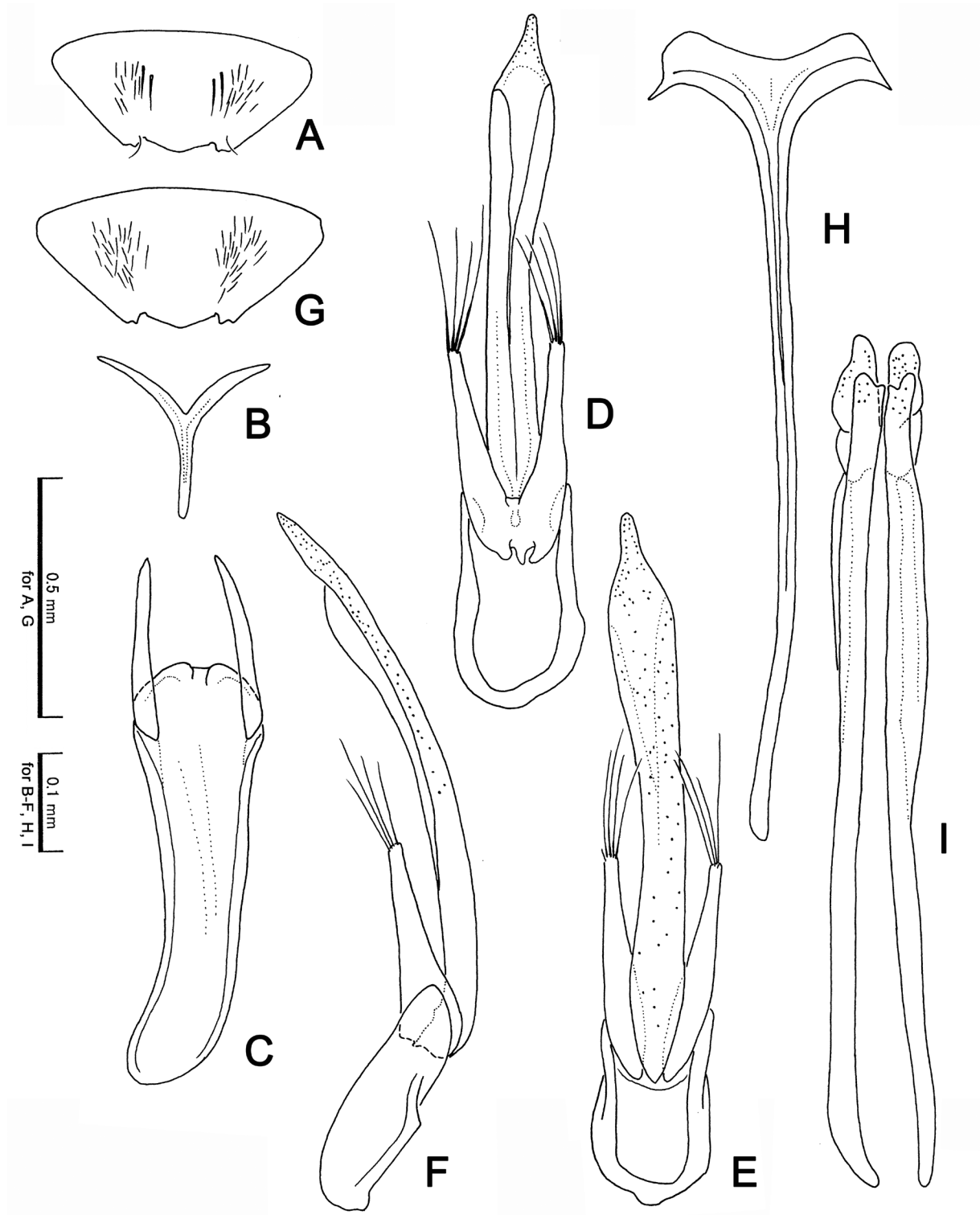

**Fig. 16.** *Mexico borneensis* sp. nov., male (A–F) and female (G–I) genitalia (holotype and paratype, BPBM). **A, G.** Sternite VII. **B.** Sternite VIII. **C.** Sternite IX. **D.** Aedeagus, ventral view. **E.** Aedeagus in dorsal view. **F.** Aedeagus in right lateral view. **H.** Urostermite. **I.** Ovipositor.

HEAD. Finely punctate, slightly convex on dorsum between eyes; distance between eyes about 0.8 times as long as eye diameter in dorsal view.

ANTENNAE. Short, reaching about anterior third of pronotum.

PRONOTUM. Closely punctate; lateral margins gently arcuate; PW/PL 2.04–2.30 (2.20). Scutellum small, square.

ELYTRA. Oval, widest at base, gently tapered posteriorly; caudal quarter of lateral margins slightly and minutely serrate; EL/EW 1.33–1.48 (1.38); EL/PL 3.11–3.70 (3.35); EW/PW 1.09–1.14 (1.11); TL/EW 1.73–1.88 (1.79).

ABDOMEN. Sternite VII (Fig. 16A) with two pairs of long and stout extra setae, bearing about 20 long setae, bifid in postero-lateral corners, gently projecting triangularly in median part of caudal margin. Sternite VIII (Fig. 16B) small, slightly sclerotized, Y-shaped. Sternite IX (Fig. 16C) well sclerotized, lightly curved in basal part; apical plates long and stout, pointed at apices.

AEDEAGUS (Fig. 16D–F). Long and slender, almost symmetrical; basal piece oval; lateral lobes short, with 4 apical setae; median lobe long and slender, subparallel-sided near base to near apex, finely punctate, with nipple-like apex; ventral plates long and slender, reaching about apical tenth of median lobe, mostly fused to median lobe; ML/BL 2.36; ML/LL 2.57.

#### Female

Sexual dimorphism slight. Sternite VII (Fig. 16G) similar to that of male, but lacking extra setae. Urosternite (Fig. 16H) well sclerotized, T-shaped, with long and slender apodeme. Ovipositor (Fig. 16I) well sclerotized; coxite sparsely punctate, obtuse at apices; apex of baculus bifid; approximate ratio of coxite and baculus ( $n = 1$ ) 1.0 : 5.5.

#### Measurements

Unsexed ( $n = 3$ ): TL 1.70–1.88 (1.81) mm; PW 0.90–0.92 (0.91) mm; PL 0.40–0.45 (0.42) mm; EL 1.30–1.48 (1.39) mm; EW 0.98–1.05 (1.01) mm.

#### Distribution

Malaysia (Labuan Island, off Borneo).

#### Remarks

This species is similar to *M. baliensis* sp. nov. in the shape of the aedeagus, but differs from it in the following characteristics: median lobe pointed at apex (obtuse in *M. baliensis* sp. nov.) and lateral lobes bearing 4 apical setae (3 in *M. baliensis* sp. nov.).

*Mexico taiwanus* (Satô, 1994) comb. nov.  
Figs 11G, 17

*Babalimnichus taiwanus* Satô, 1994: 174.

*Babalimnichus masamii* – Yoshitomi & Arai 2004: 23.

#### Material examined

JAPAN • 17 ex.; “Hikawa-hama Yonaguni-jima OKINAWA 18. VI. 2001 Koji TOYODA leg.”; EUMJ • 4 ex.; “Dannuhama Yonaguni-jima 26-VIII-1994 M. Sato leg.”; EUMJ.



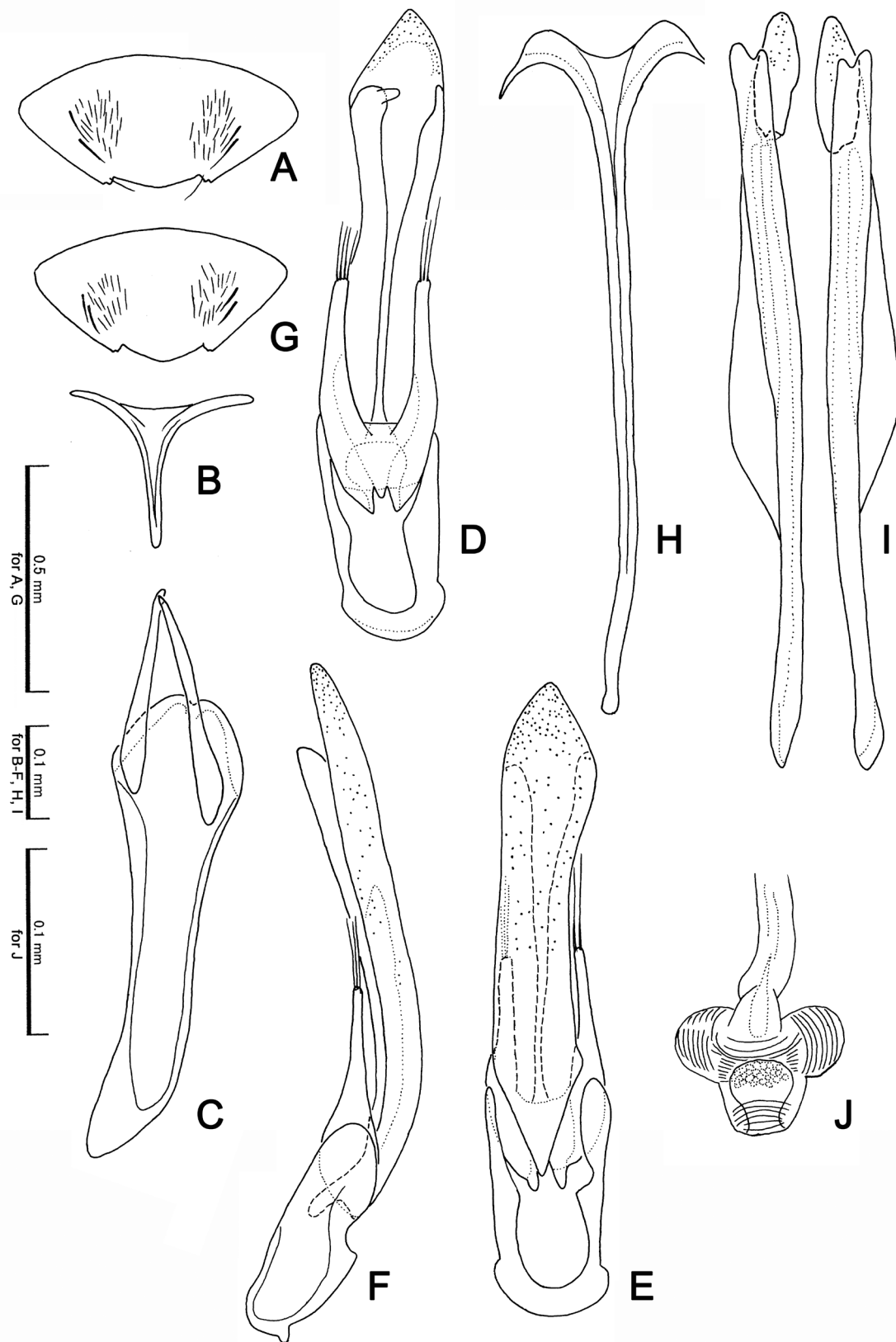

**Fig. 17.** *Mexico taiwanus* (Satô, 1994), male (A–F) and female (G–J) genitalia (EUMJ). **A, G.** Sternite VII. **B.** Sternite VIII. **C.** Sternite IX. **D.** Aedeagus, ventral view. **E.** Aedeagus in dorsal view. **F.** Aedeagus in right lateral view. **H.** Urosternite. **I.** Ovipositor. **J.** Spermatheca.

TAIWAN • 1 ♂, 1 ♀, 5 ex.; “Lung Keng Pintung Taiwan 10-VIII-2000 M. Sato leg.”; EUMJ • 1 ex.; “Mao tantou Pintung, Taiwan 10-VIII-2000 M. Sato leg.”; EUMJ • 1 ex.; “Lutao Taiwan 26-28. III. 1998 M. Sato leg.”; EUMJ • 5 ex.; “Lanhsu Taiwan 5–10. VIII. 1998 M. Sato leg.”; EUMJ • 3 ex., in ethanol; “Fushan Village Donghe Township, Taitung Country, Taiwan 1-V-2013 Tatsuya Niisato leg.”; EUMJ.

## Redescription

### Male

For a detailed description of the external features, see the original description (Satô 1994). PW/PL 1.67–2.44 (2.00); EL/EW 1.18–1.42 (1.32); EL/PL 2.33–3.40 (2.87); EW/PW 1.00–1.15 (1.09); TL/EW 1.59–1.92 (1.78).

Sternite VII (Fig. 17A) with two pairs of long, stout extra setae, bearing about 20 long setae, bifid in postero-lateral corners, gently projecting triangularly in median part of caudal margin. Sternite VIII (Fig. 17B) small, slightly sclerotized, Y-shaped. Sternite IX (Fig. 17C) slender, lightly curved in basal part; apical plates long and slender, pointed at apices. Aedeagus (Fig. 17D–F) relatively short, asymmetrical; basal piece oval; lateral lobes short, with 2–4 apical setae; median lobe a little wide, sparsely punctuate in apical part, slightly expanded in apical quarter, pointed at apex; ventral plates relatively slender, separated from median lobe, left one with thumb-like projection on inner margin of apex; ML/BL 2.42; ML/LL 2.42.

### Female

Sexual dimorphism slight. Sternite VII (Fig. 17G) similar to that of male. Urosternite (Fig. 17H) well sclerotized, with long and slender apodeme, T-shaped. Ovipositor (Fig. 17I) well sclerotized; coxite sparsely punctuate, rather pointed at apices; apices of baculus bifid; approximate ratio of coxite and baculus ( $n = 1$ ) 1.0:5.3.

## Measurements

Unsexed ( $n = 20$ ): TL 1.68–2.17 (1.95) mm; PW 0.90–1.10 (1.01) mm; PL 0.40–0.60 (0.51) mm; EL 1.28–1.62 (1.44) mm; EW 1.00–1.15 (1.10) mm.

## Distribution

Taiwan (including Lutao and Lanhsu Islands), Japan (Yonaguni-jima).

## Remarks

This is the first record of this species from Lutao and Lanhsu Islands, off Taiwan, and Yonaguni-jima.

*Mexico masamii* (Satô, 1994) comb. nov.

Figs 11F, 18–19

*Babalimnichus masamii* Satô, 1994: 175.

*Babalimnichus masamii* – Yoshitomi & Satô 2001: 472 [larval description]. — Yoshitomi 2014a: 29. — Ono *et al.* 2012: 47. — Kamezawa 2017: 54.

## Material examined

JAPAN • 7 ex.; “Japan: Honshû Nanaura-kaigan Tachibana, Sado-shi Niigata, 5. vi. 2016 37.986591, 138.234143 Kamezawa H. leg.”; EUMJ • 1 ♂; “[IZ9] Ishijirogawa, Shikinejima, Izu Isls., Japan, 34°19.409' N, 139°13.308' E, ca 16 m, 7. II. 2013, H. Yoshitomi leg.”; EUMJ • 1 ♂, 1 ♀, 14 ex.; “Kariya-kaigan Tokoname-shi Aichi Pref. 17. VIII. 1995, 17. VIII. 1995 H. Yoshitomi leg.”; 1 ♂ and 1 ♀

on slides HY 989, 992–994; EUMJ • 1 ex.; “Zoubigasaki, Murozumi Hikari-shi Yamaguchi Pref., Jpn 28. VII. 2005 Y. Fujitani leg.”; EUMJ • 5 ex.; “Bashayamamura Amami-oshima 3-V-1999 M. Sato leg.”; EUMJ • 28 ex.; “Kawata Okinawa 5-V-1999 M. Sato leg.”; EUMJ • 9 ex.; “Kim-kaigan Okinawa 28-III-1997 M. Satô leg.”; EUMJ • 1 ex.; “Onnason Okinawa-jima 26-28. IV. 2004 M. Sato leg.”; EUMJ • 1 ex.; “Kume-jima Ryukyu 30-IV-2004 M. Sato leg.”; EUMJ • 2 ex.; “Tomori Ryukyus Miyako-jima

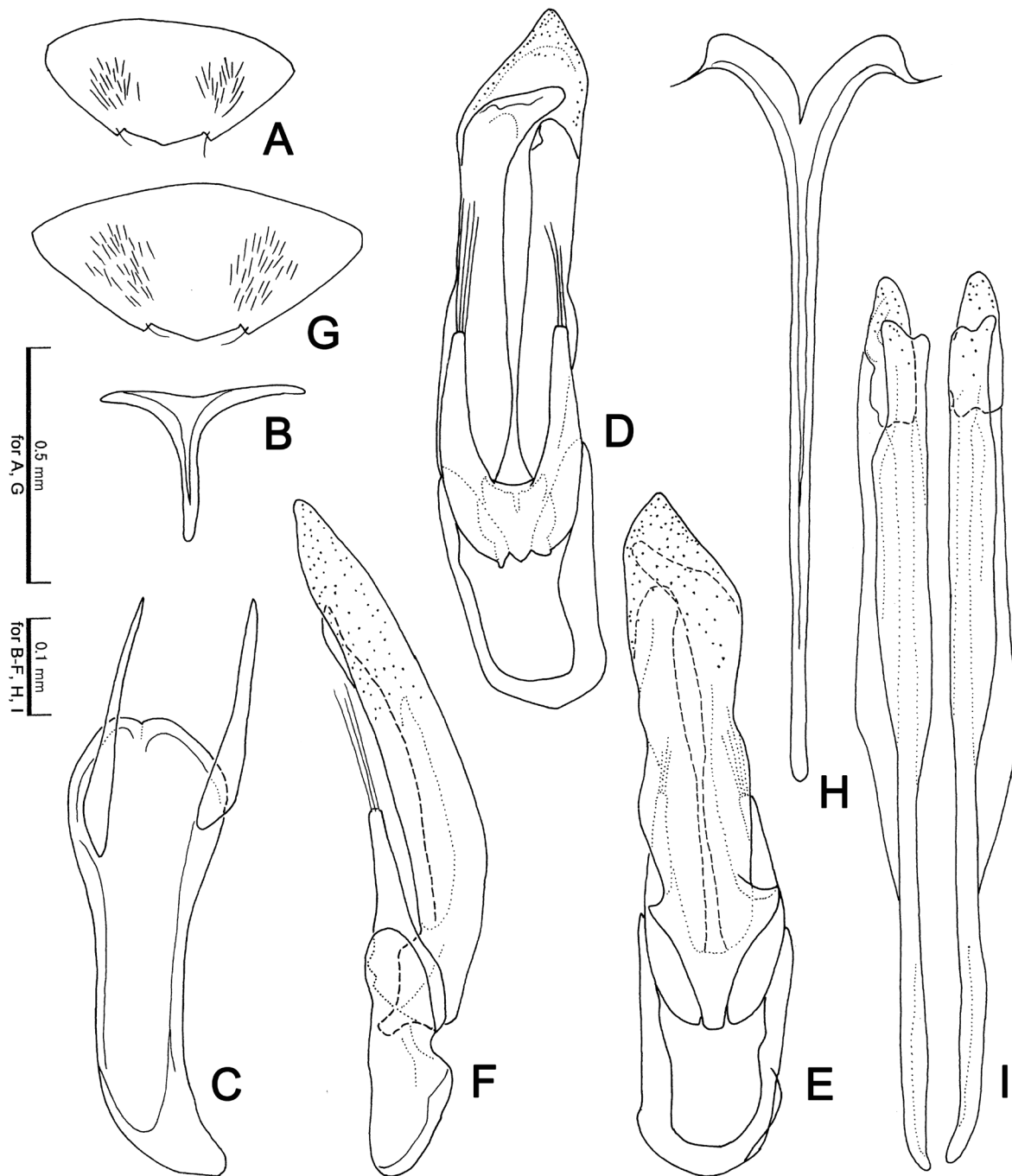

**Fig. 18.** *Mexico masamii* (Satô, 1994), male (A–F) and female (G–J) genitalia (EUMJ). **A, G.** Sternite VII. **B.** Sternite VIII. **C.** Sternite IX. **D.** Aedeagus, ventral view. **E.** Aedeagus in dorsal view. **F.** Aedeagus in right lateral view. **H.** Urosternite. **I.** Ovipositor.

7-V-1998 M. Satô leg.”; EUMJ • 13 ex.; “Uganzaki Ishigaki 22-IX-2003 M. Sato leg.”; EUMJ • 7 ex., in ethanol; “Sakaura, Izumo, Shimane 31. VII. 2006 M. Hayashi”; EUMJ • 2 pupae, with larval skins, in ethanol; “Nahama-kaigan, Nagai, Yokosuka-shi Kanagawa Pref., Japan 6. July 2007 M. Asano leg.”; EUMJ.

## Redescription

### Male

For a detailed description of the external features, see the original description (Satô 1994). PW/PL 1.67–2.22 (1.99); EL/EW 1.27–1.48 (1.36); EL/PL 2.64–3.29 (2.96); EW/PW 1.00–1.18 (1.10); TL/EW 1.71–1.95 (1.82).

Sternite VII (Fig. 18A) bearing about 30 long setae, lacking extra setae; postero-lateral corners short and pointed; median part of caudal margin gently projecting triangularly. Sternite VIII (Fig. 18B) small, slightly sclerotized, Y-shaped. Sternite IX (Fig. 18C) well sclerotized, curved in basal part, shallowly concave at apex; apical plates rather stout, pointed at apices. Aedeagus (Fig. 18D–F) relatively short, asymmetrical; basal piece oval; lateral lobes short, with 3–4 apical setae; median lobe wide, sparsely punctuate in apical part, expanded in apical quarter, gently pointed at apex; ventral plates wide, separated from median lobe, left one long and curved interiorly in apical part, right one short and straight; ML/BL 2.24; ML/LL 2.43.

### Female

Sexual dimorphism slight. Sternite VII (Fig. 18G) similar to that of male. Urosternite (Fig. 18H) well sclerotized, T-shaped, with long and slender apodeme. Ovipositor (Fig. 18I) well sclerotized; coxite sparsely punctuate, rather pointed at apices; apex of baculus bifid; approximate ratio of coxite and baculus ( $n = 1$ ) 1.0:5.9.

### Pupae

Body (Fig. 19) about 1.5 mm, cream-colored, bearing long setae on head, pronotum, elytra and abdomen.

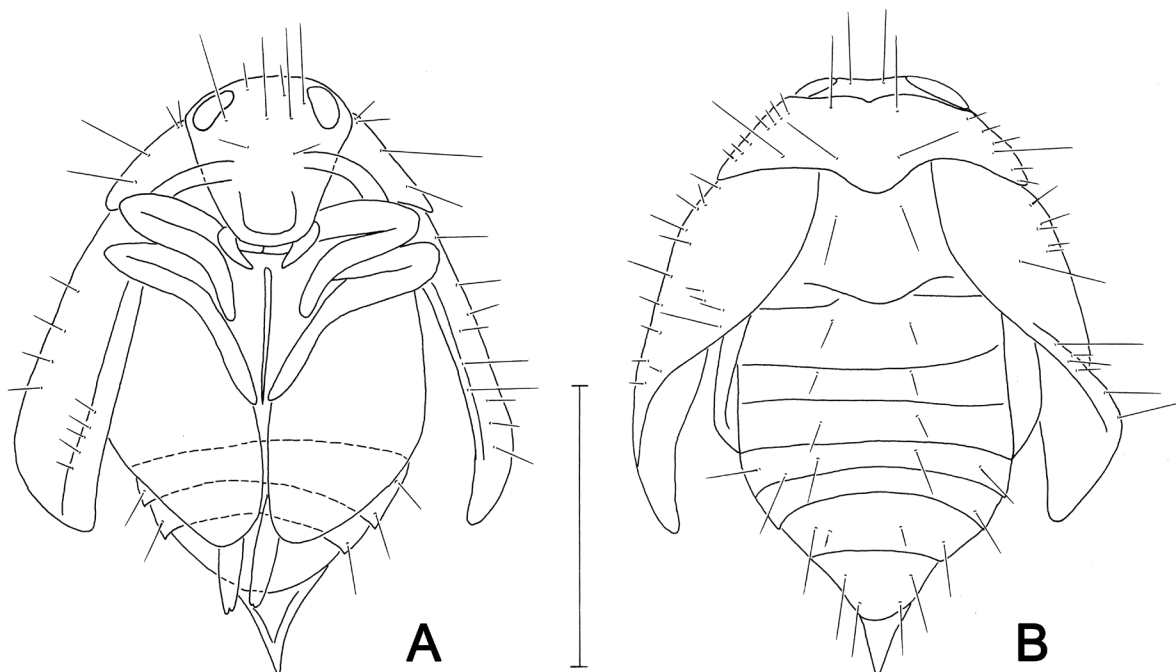

Fig. 19. Pupa of *Mexico masamii* (Satô, 1994). A. Ventral aspect. B. Dorsal aspect. Scale bar: 1.0 mm.

**Measurements**

Unsexed (n = 20): TL 1.82–2.32 (2.04) mm; PW 0.90–1.10 (1.02) mm; PL 0.45–0.60 (0.52) mm; EL 1.32–1.72 (1.53) mm; EW 1.00–1.30 (1.12) mm.

**Distribution**

Japan (Honshu, Sadogashima, Izu Islands (Shikine-jima, Kozu-shima), Shikoku, Kyushu, the Ryukyus (Yakushima, Amami-Ôshima, Tokuno-shima, Okinoerabu-jima, Yoron-tô, Okinawa-jima, Irabu-jima, Kume-jima, Miyako-jima, Ishigaki-jima)).

**Remarks**

I re-examined the specimens from Yonaguni-jima (Yoshitomi & Arai 2004), and it is clear that they do not represent this species but the preceding one. This is the first record of this species from Kume-jima.

This species has the northernmost distribution (Sado Island) in the subfamily Thaumastodinae (Kamezawa 2017).

**Biological notes**

Overwintering takes place in the larval stage in Chiba Prefecture (Ono *et al.* 2012) or the adult stage on the Izu Islands (Yoshitomi 2014a).

*Mexico splendens* (Hernando & Ribera, 2003) comb. nov.

*Babalimnichus splendens* Hernando & Ribera, 2003: 270.

**Distribution**

Tonga Islands.

**Remarks**

This species was described based on the female holotype. No additional specimens have been found.

**Phylogeny**

As a result of my analysis, one most parsimonious tree was obtained (L = 17, Ci = 88, Ri = 60), shown in Fig. 20. The synapomorphies of the subfamily Thaumastodinae are as follows: oblong body shape (1-1); eyes large, situated on dorso-lateral side of head (3-1); and hind legs with tibial spurs (9-1).

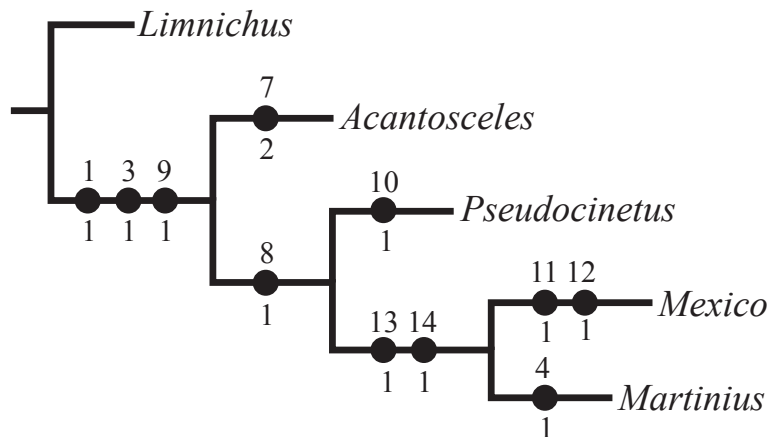

**Fig. 20.** Most parsimonious tree.

## Discussion

In the present paper, I have reviewed the Asian species and genera of the subfamily Thaumastodinae, and recognized three genera and 25 species (adding seven new species) from this area.

*Acontosceles* is an Oriental genus, living in freshwater habitats. Some unnamed species were known (Pütz 2008) because the distributional area of each species is limited and some populations were represented by female specimens only. Some new species will be described in the near future.

*Pseudeucinetus* is also an Oriental genus, living in freshwater habitats. The adults of this genus are frequently attracted to light, and the distributional area of *P. zygops* is wide, from India to Indonesia.

*Mexico* is known as a Neotropical genus, and it is newly recorded from Asia in this study. The habitat of this genus is rocky seashores, and the distributional area is mainly the Oriental and the Neotropical, extending to the Palearctic (coastal area of Japan) and the Australian (Tonga Islands) Regions. The pattern is probably not a disjunct distribution, but rather a wide distribution in the Pacific. Undescribed species are expected to be found from unrecorded areas and countries, e.g., Indochina, the Philippines, many islands of Indonesia, Australia, New Caledonia and the Pacific Islands.

*Martinius* is a Neotropical genus, represented by three species. This genus shows a sister group relationship with the genus *Mexico* (Fig. 20).

Taking into consideration the factors mentioned above, Thaumastodinae does not seem to be an example of disjunct distribution. It is probable that the main distribution area of the subfamily is the Oriental Region, and it has spread to parts of the Pacific, the Palearctic, the Australian and the Neotropical areas.

In a preliminary phylogenetic analysis using morphological characters of nine genera in four subfamilies, the monophyly of the family Limnichidae was not supported (unpublished data). In addition, the monophyly of the subfamily Limnichinae, the most diverse subfamily within the family, was also doubtful as already mentioned by Hernando & Ribera (2005a). This subfamily is subdivided into three tribes, Bothriophorini, Limnichini and Wooldridgeni, and one genus group (*Mandersia* group, sensu Hernando & Ribera 2005b) in Limnichini. Most of the genera in the subfamily Limnichinae are classified in the tribe Limnichini without a tribal definition. It is suggested that the family Limnichidae is a paraphyletic group, and the definition of the family must be reconstructed, including related families such as Heteroceridae (Crowson, 1978), Chelonariidae (Kundrata *et al.* 2017), or Dryopidae (Costa *et al.* 1999).

## Acknowledgements

Field research and collection in Hahajima was with permission of the Japan Environmental Agency, Ogasawara Board of Education, Tokyo Metropolis, and the Agency for Cultural Affairs. I thank Dr Toshio Kishimoto, Dr Tatsuya Niisato, Dr Manfred Jäch (NMW), Dr Ming-Luen Jeng (NMNS), the late Dr Masataka Satô, Dr Masami Hayashi, Dr Masakazu Hayashi, Dr Kiyoshi Ando, Dr Keiichi Takahashi, Dr Makoto Asano, Mr Hiroyuki Wakahara, Mr Hiromu Kamezawa, Mr Koji Arai, Dr Matthias Hartmann (NME) and Mr Shepherd Myers (BPBM) for supplying the material used in this paper, and Mr Dennis Murphy (The United Graduate School of Agricultural Sciences, Ehime University) for his critical reading of the draft. Part of this study was supported by KAKENHI (24510333; head investigator: H. Kojima).

## References

Beutel R.G. 1995. Phylogenetic analysis of Elateriformia (Coleoptera: Polyphaga) based on larval characters. *Journal of Zoological Systematics and Evolutionary Research* 33: 145–171.  
<https://doi.org/10.1111/j.1439-0469.1995.tb00222.x>

- Champion G.C. 1924a. On a new subfamily of clavicorn Coleoptera. *Entomologist's Monthly Magazine* 60: 25–29.
- Champion G.C. 1924b. *Thaumastodus fusiformis* Champ.: Synonymical note. *Entomologist's Monthly Magazine* 60: 116–117.
- Costa C., Vanin S.A. & Ide S. 1999. Systematics and bionomics of Cneoglossidae with a cladistic analysis of Byrrhoidea sensu Lawrence & Newton (1995) (Coleoptera, Elateriformia). *Arquivos de Zoologia, Sao Paulo* 35: 231–300. <https://doi.org/10.11606/issn.2176-7793.v35i3p231-300>
- Crowson R.A. 1978. Problems of phylogenetic relationships in Dryopoidea (Coleoptera). *Entomologica Germanica* 4: 250–257.
- Goloboff P. 1999. NONA (NO NAME) ver. 2.0. Published by the author, Tucumán, Argentina.
- Heller K.M. 1921. Philippinische Melandryidae. *Entomologische Blätter* 17 (10–12): 155–157.
- Hernando C. & Ribera I. 2003. *Babalimnichus splendens* sp. n., a new jumping shore beetle from the Tonga Islands (Polynesia) (Coleoptera: Limnichidae, Thaumastodinae). *Koleopterologische Rundschau* 73: 269–273.
- Hernando C. & Ribera I. 2005a. 18.5. Limnichidae Erichson, 1846. In: Beutel R.G. & Leschen R.A.B. (eds) *Handbook of Zoology, Volume IV (Part 38), Coleoptera, Beetles, Volume 1: Morphology and Systematics (Archostemata, Adephaga, Myxophaga, Polyphaga partim)*: 512–518. Walter de Gruyter, Berlin.
- Hernando C. & Ribera I. 2005b. *Pseudothryptus*, a new genus of Limnichidae (Coleoptera) for *Cacothryptus multiseriatus*. *Entomological Problems* 35: 131–135.
- Hinton H.E. 1939. An inquiry into the natural classification of the Dryopoidea, based partly on a study of their internal anatomy (Col.). *Transactions of the Royal Entomological Society of London* 89: 133–184. <https://doi.org/10.1111/j.1365-2311.1939.tb00739.x>
- Jäch M.A. 1998. Annotated check list of aquatic and riparian/littoral beetle families of the world (Coleoptera). In: Jäch M.A. & Ji L. (eds) *Water Beetles of China, Volume II*: 25–42. Zoologisch-Botanische Gesellschaft in Österreich/Wiener Coleopterologenverein, Vienna.
- Kamezawa H. 2017. Collecting record of *Babalimnichus masamii* from Sado Islands. *Sayabane, New Series* (25): 54. [In Japanese.]
- Kundrata R., Jäch M.A. & Bocak L. 2017. Molecular phylogeny of the Byrrhoidea-Buprestoidea complex (Coleoptera, Elateriformia). *Zoologica Scripta* 46 (2): 150–164. <https://doi.org/10.1111/zsc.12196>
- Lawrence J.F. 1988. Rhinorhipidae, a new beetle family from Australia, with comments on the phylogeny of Elateriformia. *Invertebrate Taxonomy* 2 (1): 1–53.
- Nixon K.C. 2002. WinClada ver. 1.00.08. Published by the author, Ithaca, NY.
- Ono H., Kamezawa H. & Sugaya K. 2012. Record of two seashore beetles from Chiba Prefecture. *Sayabane, New Series* (5): 47–48. [In Japanese.]
- Pütz A. 2008. Zur Kenntnis der Gattung *Acontosceles* Champion, 1924 (Coleoptera: Limnichidae: Thaumastodinae). *Koleopterologische Rundschau* 78: 305–327.
- Satô M. 1965. The limnichid-beetles of Formosa. *Special Bulletin of the Lepidopterists Society of Japan* (1): 121–125.
- Satô M. 1966. The limnichid-beetles of Japan. *Transactions of the Shikoku Entomological Society* 9 (2): 55–62.

- Satô M. 1994. Note on the genus *Pseudeucinetus* Heller and its new relative (Coleoptera, Limnichidae). *Special Bulletin of the Essa Entomological Society* 2: 173–177.
- Skelley P.E. 2005. A new species of ‘jumping shore beetle’ in the genus *Mexico* Spilman from the Bahamas (Coleoptera: Limnichidae: Thaumastodinae). *Insecta Mundi* 19 (1–2): 119–122.
- Spangler P.J. 1995. A review and two new species of the genus *Pseudeucinetus* Heller from southeast Asia and a world checklist of the Thaumastodinae (Coleoptera: Limnichidae). *Special Bulletin of the Japanese Society of Coleopterology* 4: 395–405.
- Spangler P.J., Staines C.L., Spangler P.M. & Staines S.L. 2001. A checklist of the Limnichidae and the Lutrochidae (Coleoptera) of the world. *Insecta Mundi* 15 (3): 151–165.
- Spilman T.J. 1959. A study of the Thaumastodinae, with one new genus and two new species (Limnichidae). *Coleopterist's Bulletin* 13: 111–122.
- Spilman T.J. 1966. A new species of *Martinius* from Cuba (Coleoptera: Limnichidae). *Coleopterist's Bulletin* 20: 123–125.
- Spilman T.J. 1972. A new genus and species of jumping shore beetle from Mexico. *Pan-Pacific Entomologist* 48: 108–115.
- Wooldridge D.P. 1988. *Martinius temporalis*, a new species from Ecuador (Coleoptera: Limnichidae: Thaumastodinae). *Journal of the New York Entomological Society* 96: 314–315.
- Yoshitomi H. 2004. A new record of *Pseudeucinetus zygops* (Coleoptera, Limnichidae) from Indonesia. *Elytra, Tokyo* 32: 420.
- Yoshitomi H. 2008. Contribution to the taxonomy of the genus *Laius* Guérin-Ménéville in Indonesia, with description of a new species (Coleoptera: Malachiidae). *Koleopterologische Rundschau* 78: 285–290.
- Yoshitomi H. 2014a. Water beetle fauna of Izu Islands. *Sayabane, New Series* (16): 26–31. [In Japanese, with English summary.]
- Yoshitomi H. 2014b. Comparative morphology of the endophallic structures of the genus *Laius* (Coleoptera, Melyridae), with the descriptions of three new species. *European Journal of Taxonomy* 97: 1–29. <https://doi.org/10.5852/ejt.2014.97>
- Yoshitomi H. & Arai K. 2004. *Babalimnichus masamii* collected from Yonaguni-jima. *Coleopterists' News* (148): 23. [In Japanese.]
- Yoshitomi H. & Putra N.S. 2010. Two new species of the genus *Pseudeucinetus* Heller from Indonesia and the Solomon Islands (Coleoptera: Limnichidae: Thaumastodinae). *Koleopterologische Rundschau* 80: 143–150.
- Yoshitomi H. & Putra N.S. 2011. A new species of the genus *Acontosceles* (Coleoptera, Limnichidae, Thaumastodinae) from Indonesia. *Bonn Zoological Bulletin* 60 (2): 165–168.
- Yoshitomi H. & Satô M. 2001. Description of the larva of *Babalimnichus masamii* M. Sato (Coleoptera: Limnichidae, Thaumastodinae). *Coleopterist's Bulletin* 55: 471–474.
- Yoshitomi H. & Satô M. 2005. A new species of the genus *Acontosceles* (Coleoptera, Limnichidae) from Laos, with the description of the genitalia of *A. yorioi* M. Satô. *Elytra, Tokyo* 33: 34–41.

Manuscript received: 26 March 2019

Manuscript accepted: 21 August 2019



*Published on: 4 December 2019*

*Topic editor: Gavin Broad*

*Section editor: Max Barclay*

*Desk editor: Kristiaan Hoedemakers*

Printed versions of all papers are also deposited in the libraries of the institutes that are members of the *EJT* consortium: Muséum national d'histoire naturelle, Paris, France; Meise Botanic Garden, Belgium; Royal Museum for Central Africa, Tervuren, Belgium; Royal Belgian Institute of Natural Sciences, Brussels, Belgium; Natural History Museum of Denmark, Copenhagen, Denmark; Naturalis Biodiversity Center, Leiden, the Netherlands; Museo Nacional de Ciencias Naturales-CSIC, Madrid, Spain; Real Jardín Botánico de Madrid CSIC, Spain; Zoological Research Museum Alexander Koenig, Bonn, Germany; National Museum, Prague, Czech Republic.

## Appendix 1

### List of the species of Thaumastodinae of the world

Subfamily Thaumastodinae Champion, 1924

[urn:lsid:zoobank.org:act:19F0D808-0024-490C-8253-5486727F9C9B](https://zoobank.org/urn:lsid:zoobank.org:act:19F0D808-0024-490C-8253-5486727F9C9B)

Genus *Acontosceles* Champion, 1924

[urn:lsid:zoobank.org:act:22065D0C-EF27-45ED-9A42-3FF6BBD1F02C](https://zoobank.org/urn:lsid:zoobank.org:act:22065D0C-EF27-45ED-9A42-3FF6BBD1F02C)

*Acontosceles hydroporoides* species group (sensu Pütz 2008)

*Acontosceles borneensis* sp. nov. (Malaysia [Borneo])

[urn:lsid:zoobank.org:act:2582F411-8790-4937-B6A0-248899FD9208](https://zoobank.org/urn:lsid:zoobank.org:act:2582F411-8790-4937-B6A0-248899FD9208)

*Acontosceles chujoi* Yoshitomi & Satô, 2005 (Laos, Vietnam)

[urn:lsid:zoobank.org:act:32D060AE-982D-41F3-924D-92A1096AE4CE](https://zoobank.org/urn:lsid:zoobank.org:act:32D060AE-982D-41F3-924D-92A1096AE4CE)

*Acontosceles hydroporoides* Champion, 1924 (India)

[urn:lsid:zoobank.org:act:F46F765F-6E3D-4AD2-AAD2-C13F5C261B6E](https://zoobank.org/urn:lsid:zoobank.org:act:F46F765F-6E3D-4AD2-AAD2-C13F5C261B6E)

*Acontosceles jaechi* Pütz, 2008 (Philippines [Bohol])

[urn:lsid:zoobank.org:act:255AAD2A-DA25-4E3C-909F-D1618D5EB13A](https://zoobank.org/urn:lsid:zoobank.org:act:255AAD2A-DA25-4E3C-909F-D1618D5EB13A)

*Acontosceles javanicus* Yoshitomi & Putra, 2011 (Indonesia [Java])

[urn:lsid:zoobank.org:act:A8492B62-6953-445C-AF68-25460E7CB19D](https://zoobank.org/urn:lsid:zoobank.org:act:A8492B62-6953-445C-AF68-25460E7CB19D)

*Acontosceles negrosensis* Pütz, 2008 (Philippines [Negros])

[urn:lsid:zoobank.org:act:557BCBC3-8F92-47A9-983E-F9518491A6E3](https://zoobank.org/urn:lsid:zoobank.org:act:557BCBC3-8F92-47A9-983E-F9518491A6E3)

*Acontosceles tagalog* Spilman, 1959 (Philippines)

[urn:lsid:zoobank.org:act:EBC9A1BA-BB26-4C12-B5BA-6815D1F99ECB](https://zoobank.org/urn:lsid:zoobank.org:act:EBC9A1BA-BB26-4C12-B5BA-6815D1F99ECB)

*Acontosceles yorioi* Satô, 1966 (Japan [Okinawa-jima, Iriomote-jima], Taiwan)

[urn:lsid:zoobank.org:act:4D9B9FFD-44E4-4A1F-84FA-E7173E64A7D8](https://zoobank.org/urn:lsid:zoobank.org:act:4D9B9FFD-44E4-4A1F-84FA-E7173E64A7D8)

*Acontosceles quatuordecimmaculosus* species group (sensu Pütz 2008)

*Acontosceles quatuordecimmaculosus* Pütz, 2008 (Myanmar)

[urn:lsid:zoobank.org:act:1EE4A8B9-22A6-42E4-8F51-DBD1B77B4B88](https://zoobank.org/urn:lsid:zoobank.org:act:1EE4A8B9-22A6-42E4-8F51-DBD1B77B4B88)

*Acontosceles siwalikensis* Pütz, 2008 (Nepal)

[urn:lsid:zoobank.org:act:9AE002BE-1FEF-4FB8-A3B5-A8943CB1989C](https://zoobank.org/urn:lsid:zoobank.org:act:9AE002BE-1FEF-4FB8-A3B5-A8943CB1989C)

*Acontosceles yunnanensis* Pütz, 2008 (China [Yunnan])

[urn:lsid:zoobank.org:act:64F5AC37-E237-4C0C-9615-DDB748F577C4](https://zoobank.org/urn:lsid:zoobank.org:act:64F5AC37-E237-4C0C-9615-DDB748F577C4)

*Acontosceles zetteli* Pütz, 2008 (Thailand, Laos)

[urn:lsid:zoobank.org:act:5D994D2B-317D-48B7-9AA0-3271DE288BF2](https://zoobank.org/urn:lsid:zoobank.org:act:5D994D2B-317D-48B7-9AA0-3271DE288BF2)

Genus *Martinius* Spilman, 1959

[urn:lsid:zoobank.org:act:D1657311-552F-4517-9F3E-204464C12109](https://zoobank.org/urn:lsid:zoobank.org:act:D1657311-552F-4517-9F3E-204464C12109)

*Martinius ripisaltator* Spilman, 1966 (Cuba)

[urn:lsid:zoobank.org:act:5BF966A0-9A9A-4156-904B-F4C3561AEC2D](https://zoobank.org/urn:lsid:zoobank.org:act:5BF966A0-9A9A-4156-904B-F4C3561AEC2D)

*Martinius tellipontis* Spilman, 1959 (Panama)

[urn:lsid:zoobank.org:act:1A894F79-DE95-4846-952B-039B426CC41E](https://zoobank.org/urn:lsid:zoobank.org:act:1A894F79-DE95-4846-952B-039B426CC41E)

*Martinius temporalis* Wooldridge, 1988 (Ecuador)

[urn:lsid:zoobank.org:act:E93DD6FC-2356-437F-882E-80909CC5E68B](https://zoobank.org/urn:lsid:zoobank.org:act:E93DD6FC-2356-437F-882E-80909CC5E68B)

Genus *Mexico* Spilman, 1972

[urn:lsid:zoobank.org:act:A7037F96-6A97-4838-A4B5-A3D090307D6C](https://zoobank.org/urn:lsid:zoobank.org:act:A7037F96-6A97-4838-A4B5-A3D090307D6C)

*Mexico baliensis* sp. nov. (Indonesia [Bali Island])

[urn:lsid:zoobank.org:act:98D64DE9-6A33-4EBF-A7F9-26F9A7BA409E](https://zoobank.org/urn:lsid:zoobank.org:act:98D64DE9-6A33-4EBF-A7F9-26F9A7BA409E)

*Mexico borneensis* sp. nov. (Malaysia [Borneo])

[urn:lsid:zoobank.org:act:C119FDE3-9A59-4A07-A77A-AF4C067C5D1B](https://zoobank.org/urn:lsid:zoobank.org:act:C119FDE3-9A59-4A07-A77A-AF4C067C5D1B)

*Mexico litoralis* Spilman, 1972 (Mexico)

[urn:lsid:zoobank.org:act:10667682-8B8C-4E02-9AC3-678D8B291954](https://zoobank.org/urn:lsid:zoobank.org:act:10667682-8B8C-4E02-9AC3-678D8B291954)

*Mexico masamii* (Satô, 1994) (Japan [Honshu, Izu Islands, Shikoku, Kyushu, the Ryukyus])

[urn:lsid:zoobank.org:act:85474634-5E5A-4F83-AD88-EDA6242183A0](https://zoobank.org/urn:lsid:zoobank.org:act:85474634-5E5A-4F83-AD88-EDA6242183A0)

*Mexico morrisoni* Skelley, 2005 (Bahamas)

[urn:lsid:zoobank.org:act:0D1B37BE-BF21-4679-A711-2B0C15A6AC96](https://zoobank.org/urn:lsid:zoobank.org:act:0D1B37BE-BF21-4679-A711-2B0C15A6AC96)

*Mexico ogasawaraensis* sp. nov. (Japan [Ogasawara Islands])

[urn:lsid:zoobank.org:act:8B1989C3-5D1B-4E9C-A87F-0ED19524F6D4](https://zoobank.org/urn:lsid:zoobank.org:act:8B1989C3-5D1B-4E9C-A87F-0ED19524F6D4)

*Mexico palauensis* sp. nov. (Palau)

[urn:lsid:zoobank.org:act:9A734C2D-BF7A-4F05-8628-36655720A091](https://zoobank.org/urn:lsid:zoobank.org:act:9A734C2D-BF7A-4F05-8628-36655720A091)

*Mexico papuanus* sp. nov. (Papua New Guinea)

[urn:lsid:zoobank.org:act:DB69DE47-18E6-4FA0-8D94-A9A95470D78E](https://zoobank.org/urn:lsid:zoobank.org:act:DB69DE47-18E6-4FA0-8D94-A9A95470D78E)

*Mexico splendens* (Hernando & Ribera, 2003) (Tonga Islands)

[urn:lsid:zoobank.org:act:119CC677-2FBF-4117-B0DA-3931B3A6CDF1](https://zoobank.org/urn:lsid:zoobank.org:act:119CC677-2FBF-4117-B0DA-3931B3A6CDF1)

*Mexico taiwanus* (Satô, 1994) (Taiwan, Japan [Yonaguni-jima])

[urn:lsid:zoobank.org:act:CBA7928-BE17-4A2B-AF43-1E2D35FBD09E](https://zoobank.org/urn:lsid:zoobank.org:act:CBA7928-BE17-4A2B-AF43-1E2D35FBD09E)

Genus *Pseudeucinetus* Heller, 1921

[urn:lsid:zoobank.org:act:08D0E4C3-6D24-4A42-BB38-961E6BA85773](https://zoobank.org/urn:lsid:zoobank.org:act:08D0E4C3-6D24-4A42-BB38-961E6BA85773)

*Pseudeucinetus javanicus* Yoshitomi & Putra, 2010 (Indonesia [Java, Lombok])

[urn:lsid:zoobank.org:act:9766FA9E-388C-455E-883E-7FEF7DE27D2A](https://zoobank.org/urn:lsid:zoobank.org:act:9766FA9E-388C-455E-883E-7FEF7DE27D2A)

*Pseudeucinetus novabritannica* Delève, 1973 (Bismarck Archipelago [New Britain])

[urn:lsid:zoobank.org:act:D4F058A4-8841-48EF-B1EA-03BA40B1B6E2](https://zoobank.org/urn:lsid:zoobank.org:act:D4F058A4-8841-48EF-B1EA-03BA40B1B6E2)

*Pseudeucinetus papuanus* sp. nov. (Papua New Guinea)

[urn:lsid:zoobank.org:act:978D5D6D-8D48-425D-AB1B-0536A2E10753](https://zoobank.org/urn:lsid:zoobank.org:act:978D5D6D-8D48-425D-AB1B-0536A2E10753)

*Pseudeucinetus solomonicus* Yoshitomi & Putra, 2010 (Solomon Islands [Santa Catalina, Santa Anna])

[urn:lsid:zoobank.org:act:113B8D47-F5AA-4EC7-8F07-9921CB8347D8](https://zoobank.org/urn:lsid:zoobank.org:act:113B8D47-F5AA-4EC7-8F07-9921CB8347D8)

*Pseudeucinetus spilmani* Spangler, 1995 (Indonesia [Bacan])

[urn:lsid:zoobank.org:act:9DAB932B-0495-4EE9-B97D-AAA873871A2E](https://zoobank.org/urn:lsid:zoobank.org:act:9DAB932B-0495-4EE9-B97D-AAA873871A2E)

*Pseudeucinetus uenoi* Spangler, 1995 (Malaysia [Borneo])

[urn:lsid:zoobank.org:act:5CC8AB17-8B02-4170-97C2-7A18F85D751D](https://zoobank.org/urn:lsid:zoobank.org:act:5CC8AB17-8B02-4170-97C2-7A18F85D751D)

*Pseudeucinetus zygops* Heller, 1921 (India, Malaysian Peninsula, Bismarck Islands [New Ireland], the Philippines [Balabac, Palawan, Mindanao, Negros], Indonesia [Sulawesi])

[urn:lsid:zoobank.org:act:7903C913-85A7-4AE6-B4E4-619A86BB46CB](https://zoobank.org/urn:lsid:zoobank.org:act:7903C913-85A7-4AE6-B4E4-619A86BB46CB)

## **Appendix 2**

### **Characters used in the phylogenetic analysis**

Character 1. Body shape: oval (0); oblong (1).

Character 2. Reception of legs in venter: absent (0); present (1)

Character 3. Eyes: moderate size, situated on lateral side of head (0); large size, situated on dorso-lateral side of head (1).

Character 4. Antennal segments: 11 (0); 7 (1).

Character 5. Antennae inserted: near eyes (0); near mandibles (1).

Character 6. Antennal groove on gena: absent (0); present (1).

Character 7. Tarsal formula: 5-5-5 (0); 4-4-4 (1); 4-5-5 (2).

Character 8. Hind coxa: normally visible ventrally (0); hidden by hind coxal plate and invisible ventrally (0).

Character 9. Hind legs: without tibial spurs (0); with tibial spurs (1).

Character 10. Male fore tarsi: normal (0); enlarged (1).

Character 11. Aedeagus: without extra plate (0); with ventral plates (1).

Character 12. Male genitalia: lateral lobe with short setae and punctures (0); with extra long setae (1).

Character 13. Male genitalia: medial lobe shorter than lateral lobe (0); longer than lateral lobe (1).

Character 14. Female genitalia: coxite pointed at apex, attached in apical part of bacillus (0); obtuse and bifid at apex, attached in apical sixth of baculus (1).

**Appendix 3****Data matrix for phylogenetic analysis**

<b>Character no.</b>	<b>1</b>	<b>2</b>	<b>3</b>	<b>4</b>	<b>5</b>	<b>6</b>	<b>7</b>	<b>8</b>	<b>9</b>	<b>10</b>	<b>11</b>	<b>12</b>	<b>13</b>	<b>14</b>
<i>Acontosceles</i>	1	0	1	0	0	0	2	0	1	0	0	0	0	0
<i>Pseudeucinetus</i>	1	0	1	0	1	1	1	1	1	1	0	0	0	0
<i>Mexico</i>	1	0	1	0	0	1	1	1	1	0	1	1	1	1
<i>Martinius</i>	1	0	1	1	1	0	1	1	1	0	0	0	1	1
<i>Limnichus</i>	0	1	0	0	0	0	0	0	0	0	0	0	0	0