

The syntax and semantics of left-node raising in Japanese

Shūichi Yatabe

University of Tokyo

Abstract

In this paper, I argue (i) that Japanese has constructions that are almost the exact mirror images of the right-node raising constructions in English, and (ii) that the properties of those constructions, which I refer to as left-node raising constructions, can be captured straightforwardly if and only if the CONTENT values of domain objects, not those of signs, are assumed to be the principal locus of meaning assembly. In the theory proposed, it is claimed that semantic composition (including ‘quantifier retrieval’) takes place not when some signs are syntactically combined to produce a new, larger sign but when some domain objects (which are essentially prosodic constituents) are merged (by the total or partial compaction operation) to produce a new domain object (i.e. a new, larger prosodic constituent).

1 Introduction

This paper has two goals; the first goal is to show that Japanese has constructions that are almost the exact mirror images of the right-node raising (RNR) constructions in English, and the second goal is to demonstrate that the properties of those constructions, which I will refer to as left-node raising (LNR) constructions, can be captured straightforwardly if and only if the CONTENT values of domain objects, not those of signs, are assumed to be the principal locus of semantic composition. I will be concerned with the first, descriptive goal in section 2, and then will turn my attention to the second, theoretical goal in sections 3, 4, and 5.

2 The existence of left-node raising in Japanese

Let me start by defining the term *left-node raising (LNR)*. In this paper, the term *left-node raising* will be used to refer to a grammatical mechanism that ‘strips off’ the left edges of conjuncts or what might be called quasi-conjuncts and ‘dislocates’ them out of the entire coordinate structure, or what might be called a quasi-coordinate structure. To put it differently, left-node raising is a grammatical operation that turns an expression of the form *XYXZ* (where *XY* and *XZ* are typically conjuncts) into an expression of the form *XYZ*. Given this definition, can Japanese be said to have left-node raising? This question turns out not to be easy to answer, because of the existence of null anaphora in the language. For instance, the example in (1), which is analyzable as the result of left-node-raising the NP *Ken* out of two larger NPs (‘those who praised Ken’ and ‘those who bad-mouthed Ken’), does not provide evidence that Japanese has LNR, because it is also analyzable as a simple coordinate structure consisting of two conjuncts (‘those who praised Ken’ and ‘those who bad-mouthed him’), the second of which contains a zero pronoun serving as the object of the verb *kenashita*.

- (1) Ken o hometa hito to kenashita hito
Ken ACC praise-PAST person and bad-mouth-PAST person
‘those who praised and those who bad-mouthed Ken’

To the best of my knowledge, no one has ever argued that Japanese has LNR. There are, however, several types of facts that demonstrate that it does.

2.1 The first argument: infinitival complements

The first argument for postulation of LNR in Japanese comes from the behavior of infinitival complements. Unlike NPs, infinitival complements cannot be left unpronounced in Japanese, as shown by the fact that (2b) but not (2c) can be uttered as an appropriate answer to the question in (2a)

- (2) a. Yonde ageta?
read-GER 'give'-PAST
'Did (you) give (him/her) the favor of reading (it) (to him/her)?'
- b. Iya, yonde agenakatta.
no read-GER 'give'-NEG-PAST
'No, (I) did not give (him/her) the favor of reading (it) (to him/her).'
- c.*Iya, agenakatta.

Thus the example in (3) constitutes evidence that Japanese allows LNR. If Japanese did not have left-node raising, (3) would have to be as unacceptable as (2c). Here and throughout the rest of this paper, the elements that I claim have been left-node-raised are capitalized, and the conjuncts (and what might be called "quasi-conjuncts") that I claim those elements have been left-node-raised out of are enclosed in angle brackets (" $<$ " and " $>$ ").

- (3) YONDE $<$ ageta hito $>$ to $<$ agenakatta hito $>$ ga ita.
read-GER $<$ 'give'-PAST person $>$ and $<$ 'give'-NEG-PAST person $>$ NOM be-PAST
'There were people who gave (him/her) the favor of reading (it) (to him/her) and people who didn't.'

2.2 The second argument: compound fragments

The second argument is based on the observation that Japanese does not allow part of a compound to be left unpronounced, as shown by the contrast between (4b) and (4c). (4b) but not (4c) can be uttered as an appropriate answer to the question in (4a). (The verb *omoidas-* 'recall' that is used in these examples is a compound verb made up of two verb stems, *omoi-* 'to think' and *das-* 'to get (something) out'.)

- (4) a. Omoidashita?
recall-PAST
'Can (you) recall it?'
- b. Iya, omoidasanai.
no recall-NEG-PRES
'No, (I) cannot recall (it).'
- c.*Iya, dasanai.

Given this observation, the fact that not only (5a) but also (5b) is acceptable shows that Japanese allows left-node raising of part of a compound.

- (5) a. [Omoidasu ka] [omoidasanai ka] ga mondai da.
[recall-PRES Q] [recall-NEG-PRES Q] NOM problem COP-PRES
'Whether (you) can recall (it) or (you) cannot recall (it) is the problem.'
- b. OMOI $<$ dasu ka $>$ $<$ dasanai ka $>$ ga mondai da.

We know that what we are looking at here is a compound and not a sequence of two words, as absolutely nothing can intervene between its first and second halves, as shown in (6).

- (6) *omoi o/ni/... dasu

Note that the acceptability of an example like (5b) shows not only that Japanese has an operation that turns an expression of the form *XYXZ* into an expression of the form *XYZ* but also that the effects of this operation are radically different from the types of effects that are standardly analyzed in terms of across-the-board propagation of the *SLASH* feature in HPSG. Note also that it is not surprising that LNR in Japanese should be permitted to affect part of a compound, as RNR in English is also permitted to affect part of a compound, as in *pre- and post-war* (see Booij (1984) for analogous Dutch and German examples).

2.3 The third argument: idiom chunks

The third argument is based on the behavior of idiom chunks. Japanese does not allow part of a noncompositional idiom (Nunberg et al. (1994)) to be left unpronounced, as shown by the fact that (7b) but not (7c) can be uttered as an appropriate answer to the question in (7a).

- (7) a. Nihonjin ga me ni tsuita?
 Japanese NOM eye DAT adhere-PAST
 ‘Did a lot of Japanese people adhere to (your) eyes?’ (lit.)
 ‘Did (you) see a lot of Japanese people there?’
- b. Iya, me ni tsukanakatta.
 no eye DAT adhere-NEG-PAST
 ‘No, (a lot of Japanese people) didn’t adhere to (my) eyes.’ (lit.)
 ‘No, I didn’t see (a lot of Japanese people).’
- c.*Iya, tsukanakatta.

Thus the acceptability of the example in (8) indicates that Japanese allows LNR.

- (8) ME NI <tsuku toki> to <tsukanai toki> ga atta.
 eye DAT <adhere-PRES time> and <adhere-NEG-PRES time> NOM be-PAST
 ‘There were times when (I) saw (a lot of Japanese) and times when (I) did not see (a lot of Japanese).’

2.4 The fourth argument: wh-phrases

The fourth argument is based on the behavior of wh-phrases. In Japanese, a wh-phrase that causes a clause to be interpreted as a wh-question cannot be left unpronounced. For instance, the second occurrence of the wh-phrase *nani o* in example (9) cannot be left unpronounced, if the second bracketed clause in this example is to be interpreted as a wh-question.

- (9) [Ken ga nani o nusunda no ka] wa wakatte iru ga, [Naomi ga *(nani
 [Ken NOM what ACC steal-PAST NML Q] TOP understand-GER be-PRES although [Naomi NOM what
 o) urisabaita no ka] wa wakatte inai.
 ACC sell-PAST NML Q] TOP understand-GER be-NEG-PRES
 ‘Although we know what Ken stole, we don’t know what Naomi sold.’

Thus, the fact that both embedded clauses in example (10) can be interpreted as wh-questions indicates that Japanese has LNR.

- (10) NANSATSU NO HON O <Ken ga nusunda no ka>, soshite <Naomi ga urisabaita
 how many volumes GEN book ACC <Ken NOM steal-PAST NML Q> and <Naomi NOM sell-PAST
 no ka>, wakatte inai.
 NML Q> understand-GER be-NEG-PRES
 ‘We don’t know how many books Ken stole and Naomi sold.’

2.5 The fifth argument: quantifier scope

The final argument for the existence of LNR in Japanese comes from the interpretation of quantifiers. A quantified NP contained inside a disjunct cannot take scope over the disjunction. This is illustrated in (11).

- (11) [Asu made ni nana-satsu-ijô no hon no shohyô o kaku ka] [kyôjû ni
 [tomorrow until DAT 7 or more volumes GEN book GEN review ACC write-PRES Q] [within today DAT
 yôyaku o sakusei suru ka] shinakereba naranai.
 summary ACC make-PRES Q] do-NEG-PROV become-NEG-PRES
 ‘(I) must either write a review of seven or more books by tomorrow or make a summary (of seven or
 more books) today.’

In (11), the quantifier *nana-satsu-ijô no hon* ‘seven or more books’ cannot take scope over the disjunction expressed by *ka*, and thus the sentence does not have a meaning paraphrasable as “The number of books that I write a review of by tomorrow and the number of books that I make a summary of today must add up to seven or more.” In contrast, in (12) below, the quantifier *can* take scope over the disjunction, and the sentence has a meaning that is paraphrasable as “I must review or summarize some books, totaling seven or more” or, equivalently, “The number of books that I write a review of and the number of books that I make a summary of must add up to seven or more.”

- (12) NANA-SATSU-IJÔ NO HON NO <shohyô o kaku ka> <yôyaku o sakusei suru ka>
 7 or more volumes GEN book GEN <review ACC write-PRES Q> <summary ACC make-PRES Q>
 shinakereba naranai.
 do-NEG-PROV become-NEG-PRES
 ‘(I) must either write a review or make a summary of seven or more books.’

Assuming that we are justified in believing that a quantifier inside a disjunct generally cannot take scope over the disjunction, the fact that the quantifier ‘seven or more books’ in (12) can take scope over the disjunction indicates that Japanese is equipped with a grammatical mechanism that ‘strips off’ the left periphery of a conjunct and ‘raises’ it out of the entire coordinate structure, i.e. LNR.

Thus I conclude that Japanese does have left-node raising. Japanese and English are mirror images of each other in this regard, just as they are mirror images with regard to complementation and so on. I think that this descriptive conclusion might be of some interest even to those who are not interested in Japanese syntax, because it tends to refute the view that right-node raising does not resemble anything else in our grammatical system and hence might as well be relegated to the extragrammatical processing module of our linguistic ability.

3 Properties of the left-node raising constructions

In this section, I am going to enumerate some of the syntactic and semantic properties of LNR in Japanese which any theory of the phenomenon will have to capture. LNR in Japanese turns out to be strikingly similar to RNR in languages like English, both syntactically and semantically. Accordingly, I will occasionally use the term *node raising* as a term that refers to right-node raising as well as left-node raising.

First, LNR in Japanese can dislocate a string which does not form a morphosyntactic constituent. This is shown by (13), in which the string *nihonjin ga me ni*, which is a sequence of two NPs and does not form a constituent, has been left-node-raised.

- (13) NIHONJIN GA ME NI <tsuku toki> to <tsukanai toki> ga atta.
 Japanese NOM eye DAT <adhere-PRES time> and <adhere-NEG-PRES time> NOM be-PAST
 ‘There were times when (I) saw a lot of Japanese and times when (I) did not see a lot of Japanese.’

This observation is reminiscent of the fact that RNR in English is permitted to dislocate a non-constituent, as shown by the examples in (14). No matter how you look at them, these examples both involve right-node

raising of a non-constituent string.¹

(14) (from Wilder (1997))

- a. He looked a word with ten and she looked a word with twenty letters up in the dictionary.
- b. a positively and a negatively charged particle

An important fact to note here is that the linear order between the things that are left-node-raised or right-node-raised is always preserved; it is never disrupted. For instance, in example (14b), it is not possible to reverse the order between the word *charged* and the word *particle*. Likewise, in example (13), it is impossible to reverse the order between the nominative NP and the dative NP at the beginning of the sentence, because an argument of an idiomatic predicate must precede chunks of that idiomatic predicate, independently of left-node raising. These observations strongly suggest that left-node raising and right-node raising cannot be given an analysis in terms of the SLASH feature. If sentences like (13) and (14) are analyzed in terms of across-the-board propagation of the SLASH feature, it is not clear what will prevent the linear order between the two node-raised expressions from being disrupted.

The second observation that I wish to make is that it is possible to left-node-raise an expression out of phrases that do not form a coordinate structure, as shown by (15).

(15) YONDE <ageta hitotachi kara> <agenakatta hitotachi e> no messêji
read-GER <'give'-PAST people from> <'give'-NEG-PAST people to> GEN message
'a message from the people who gave (him/her) the favor of reading (it) (to him/her) to the people who didn't.'

This observation is reminiscent of the fact that an expression can be right-node-raised out of a non-coordinate structure in English, as in examples such as (16).

- (16) a. independence of local from central government
- b. It's interesting to compare people who like with the people who dislike the power of the big unions.
(from Hudson (1976))

Third, as I have already mentioned in section 2, a part of a morphological word can be left-node-raised. We saw an example of this in (5b) above. This observation is reminiscent of the fact that a part of a morphological word can be right-node-raised in English, as in the examples listed in (17).

(17) (from Wilder (1997))

- a. the in- and the output of this machine
- b. We must distinguish psycho- from sociolinguistic claims.

I believe this observation favors an analysis of node raising in terms of linearization. Analyses in terms of the SLASH feature, for instance, predict that what can be left-node-raised or right-node-raised must be a sequence of morphosyntactic units. On the other hand, a linearization-based theory does not make such an erroneous prediction. In a linearization-based analysis, it is possible, and in fact quite natural, to say that what are right-node-raised or left-node-raised are prosodic constituents, rather than morphosyntactic constituents. In such an analysis, the acceptability of examples like those in (5b) and (17) merely means that some morphological words are made up of more than one prosodic word.²

Incidentally, there is one superficial difference between RNR in English and LNR in Japanese: the latter does not allow postposition stranding, while the former allows preposition stranding. (Here I am using the term *postposition* to refer to particles such as *ga* and *o*, which some people analyze as postpositions.) On

¹The examples in (14) demonstrate what they are supposed to demonstrate more convincingly than the examples that Abbott (1976) used to make the same point.

²See Poser (1990) for a convincing demonstration that some morphological words in Japanese actually contain more than one prosodic word.

the assumption that it is prosodic constituents that are affected by node raising, however, this contrast can be understood as a trivial consequence of the fact that a postposition in Japanese and the morphological word preceding it are always phonologically merged to become a single prosodic word.

Finally, although it has all the earmarks of being a ‘stylistic rule,’ LNR sometimes has an effect on semantic scope relations, as shown by the contrast between (11) and (12) above. This observation is reminiscent of the fact that RNR in English sometimes has an effect on semantic scope relations, as McCawley (1982: n.12) noted with regard to examples like (18a) and (18b).

(18) (from McCawley (1982))

- a. Karsh took photographs and Wyeth painted portraits of many famous persons.
- b. Karsh took photographs of many famous persons and Wyeth painted portraits of many famous persons.

(18a), but not (18b), is ambiguous between the following two interpretations:³ ‘There are many famous persons such that Karsh took photographs of them and Wyeth painted portraits of them,’ and ‘There are many famous persons such that Karsh took photographs of them, and there is a possibly different set of many famous persons such that Wyeth painted portraits of them.’

As far as the examples in (18a) and (18b) are concerned, it might be possible to claim that the only difference between the two examples is the number of quantifiers involved. In other words, it might be possible to say that right-node raising merely collapsed two quantifiers into one, without really affecting the scope of the quantifiers. However, the contrast between (11) and (12) above cannot be trivialized in that way. As I mentioned, the quantifier cannot take scope over the disjunction in (11), whereas it *can* take scope over the disjunction in (12). Clearly, left-node raising has not simply affected the number of quantifiers; it has affected scope relations.

At first blush, this final observation seems to pose a problem for a linearization-based analysis. It would appear that Categorical Grammar analyses (e.g. Steedman (2000)) would do a lot better in this regard. As I will argue below, however, the observation in question does not necessarily favor Categorical Grammar analyses.

4 A linearization-based analysis of left-node raising

In this section, I am going to present a linearization-based theory of LNR.

Some of the properties of LNR that I discussed in section 3 strongly suggest that LNR should be given a linearization-based analysis. But a simple-minded attempt to construct a linearization-based theory of LNR encounters the following two problems. First, as I have just noted, LNR sometimes has a semantic effect. This poses a problem for any attempt to develop a linearization-based theory of LNR, as long as semantic composition is assumed (as it usually is) to take place without reference to what happens in order domains. Second, even what cannot be extraposed (or long-distance-scrambled) can be left-node-raised (see for example (5b) above). This means that we cannot simply model our theory of node raising after a successful linearization-based theory of extraposition such as Kathol and Pollard’s (1995).

Let me start with the second problem. In order to solve this second problem, I propose (i) to represent prosodic constituency within order domains along the lines suggested by Donohue and Sag (1999) and (ii) to allow prosodic constituents (which are embedded inside domain objects) as well as domain objects to be left-node-raised. Figure 1 shows a structure that I claim results from LNR of a domain object, and Figure 2 shows a structure that I claim results from LNR of a prosodic constituent. In these figures, the first and the second line of a sign schematically represent its SYNSEM|CAT value and its order domain respectively, and the first and the second line of a domain object schematically represent its PHON value and its SYNSEM|CAT value respectively.⁴

³Kehler et al. (1999) dispute the observation that RNR of a quantifier can create scopal ambiguity, but they do not deny that RNR can have an effect on scope relations.

⁴These figures are based on the assumption that a string consisting of a verb stem, a negative morpheme *-(a)na*, and a tense suffix forms a morphosyntactic constituent. This assumption is probably false, as claimed in Yatabe (1998); I make this assumption in this paper in order to simplify the exposition. Likewise, I disregard the effects of cliticization in these figures.

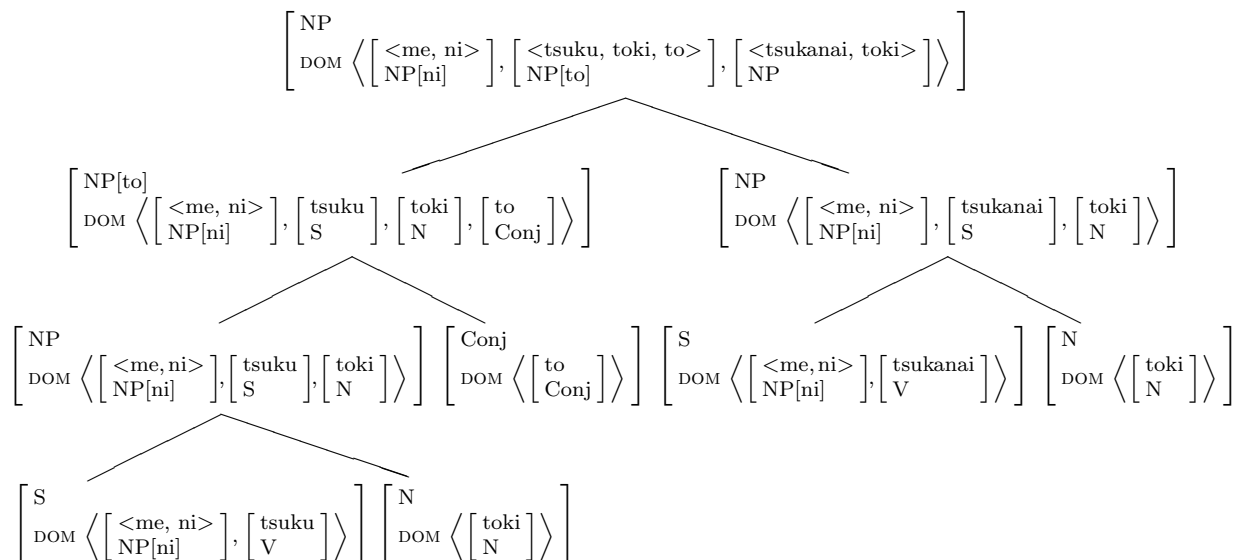

Figure 1: Left-node raising of a domain object (see (8))

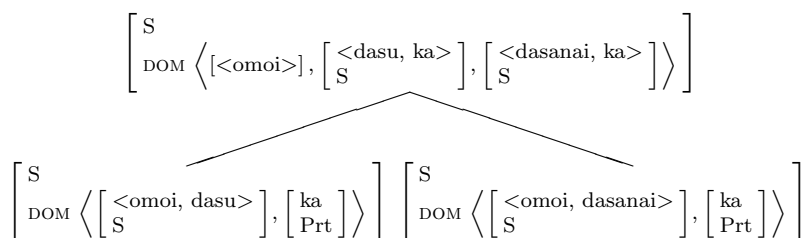

Figure 2: Left-node raising of a prosodic constituent (see (5b))

One way to formalize the proposed account is shown in (19) through (23). The symbol “ \circ ” which I use in (19) designates the shuffle operation.

(19) Suppose $\boxed{1} \cdots \boxed{n}$ are the daughters of the phrase $\boxed{0}$ and the DOM value of $\boxed{0}$ is $\boxed{d_0}$. If $n = 1$, then the relation between $\boxed{d_0}$ and $\boxed{1}$ must conform to the conditions stated in (30). If $n \geq 2$, then the relation between $\boxed{d_0}$ and $\boxed{1} \cdots \boxed{n}$ must conform either to the conditions stated in (30) or to one of the two conditions stated below.

- (i) $\exists \boxed{K} [\boxed{K} \neq \langle \rangle \ \&$
 $\boxed{d_0} = \boxed{K} \oplus$
 $(\langle \text{totally_compact}(\text{cut_left}(\boxed{K}, \boxed{1})) \rangle \circ \cdots \circ \langle \text{totally_compact}(\text{cut_left}(\boxed{K}, \boxed{n})) \rangle)]$
- (ii) $\exists \boxed{k} [\boxed{k} \neq \langle \rangle \ \&$
 $\boxed{d_0} = \langle \text{add_synsem}(\boxed{k}) \rangle \oplus$
 $(\langle \text{totally_compact}(\text{chop_left}(\boxed{k}, \boxed{1})) \rangle \circ \cdots \circ \langle \text{totally_compact}(\text{chop_left}(\boxed{k}, \boxed{n})) \rangle)]$

$$(20) \text{cut_left} \left(\boxed{a}, \left[\begin{array}{c} \text{SYNSEM} \ \boxed{1} \\ \text{DOM} \ \boxed{b} \end{array} \right] \right) = \left[\begin{array}{c} \text{SYNSEM} \ \boxed{1} \\ \text{DOM} \ \text{subtract_left}(\boxed{a}, \boxed{b}) \end{array} \right]$$

(21) $\text{subtract_left}(\boxed{a}, \boxed{b})$ is

- (i) the non-empty list \boxed{c} such that $\boxed{a} \oplus \boxed{c} = \boxed{b}$, if such \boxed{c} exists, and
- (ii) undefined, otherwise.

$$(22) \text{add_synsem}(\boxed{k}) = \left[\begin{array}{c} \text{dom-obj} \\ \text{SYNSEM} \left[\begin{array}{c} \text{CONT} \left[\begin{array}{c} \text{LTOP} \ \text{none} \\ \text{INDEX} \ \text{none} \\ \text{EP} \ \langle \rangle \\ \text{H-CONS} \ \{ \} \\ \text{H-STORE} \ \{ \} \end{array} \right] \\ \text{CAT} \left[\begin{array}{c} \text{HEAD} \ \text{none} \\ \text{COMPS} \ \langle \rangle \\ \text{EXTRA} \ - \end{array} \right] \end{array} \right] \\ \text{PHON} \ \boxed{k} \end{array} \right]$$

$$(23) \text{chop_left} \left(\boxed{a}, \left[\begin{array}{c} \text{SYNSEM} \ \boxed{1} \\ \text{DOM} \ \left\langle \left[\begin{array}{c} \text{SYNSEM} \ \boxed{2} \\ \text{PHON} \ \boxed{b} \end{array} \right] \right\rangle \oplus \boxed{c} \right] \right) \\ = \left[\begin{array}{c} \text{SYNSEM} \ \boxed{1} \\ \text{DOM} \ \left\langle \left[\begin{array}{c} \text{SYNSEM} \ \boxed{2} \\ \text{PHON} \ \text{subtract_left}(\boxed{a}, \boxed{b}) \end{array} \right] \right\rangle \oplus \boxed{c} \right]$$

On this account, the difference between LNR and extraposition is ascribed to the former’s ability vs. the latter’s inability to alter the internal structure of domain objects. This way, the proposed analysis captures both the similarities and the differences between node raising and extraposition. Because it is linearization-based, this analysis captures in a straightforward manner the fact that both node raising and extraposition are allowed to affect only the left or the right edge of an expression, unlike grammatical processes such as relativization and topicalization. At the same time, the proposed analysis captures a crucial difference between node raising and extraposition by allowing the former but not the latter to affect a prosodic constituent which is contained in but does not constitute a domain object.

Next, let us return to the first problem, that is, the problem posed by the fact that left-node raising sometimes affects scope relations. The solution I propose for this problem involves a rather major reorganization of the way semantic composition is carried out in HPSG. The basic idea behind the proposal is that domain

objects, and not signs, are the principal carriers of semantic information and that semantic composition (including ‘quantifier retrieval’) takes place not when some signs are syntactically combined to produce a new, larger sign but when some domain objects are (either totally or partially) compacted to produce a new domain object. In order to implement this idea, I adopt the framework of Minimal Recursion Semantics (Copestake et al. (1997))⁵ and assume that the *total compaction* operation (in Kathol and Pollard’s (1995) sense) is defined as in (24)⁶ and the *partial compaction* operation is defined as in (26). The names HNDL, LTOP, and H-CONS, which have been borrowed from Copestake et al. (1999), stand for “handle,” “local top,” and “handle constraints” respectively. The name H-STORE, which has been borrowed from Copestake et al. (1997), stands for “handle store.” The value of the HNDL feature shows the handle of each elementary predication; the value of the LTOP feature shows the local top handle of each sign and domain object; the H-CONS feature is used to represent constraints that are imposed on handles; and the H-STORE feature is used as quantifier storage (‘Cooper storage’). What is called EP (“elementary predications”) in (24) is essentially what is called LZT in Copestake et al. (1999) (which in turn is the same as what is called LISZT in Copestake et al. (1997)); the value of this feature is the list of elementary predications that make up the meaning of a given linguistic unit (a sign, in the case of Copestake et al.’s (1999) theory, and either a sign or a domain object, in the case of the theory developed below). The name SEMHEAD is, perhaps obviously, meant to stand for “semantic head”; the value of this feature on sign α represents the local top handle of the semantic head of α . The value of the TO-BE-STORED feature is the set of the quantifier handles that are to be put in storage, which is either an empty set or a singleton.

$$(24) \left[\begin{array}{l} \textit{sign} \\ \text{SYNSEM} \left[\begin{array}{l} \text{CONT} \left[\begin{array}{l} \text{LTOP} \quad \boxed{0} \\ \text{INDEX} \quad \boxed{1} \\ \text{SEMHEAD} \quad \boxed{2} \end{array} \right] \\ \text{CAT} \quad \boxed{3} \quad \text{[TO-BE-STORED} \quad \boxed{4}] \end{array} \right] \\ \text{DOM} \left\langle \begin{array}{l} \text{SYNSEM|CONT} \left[\begin{array}{l} \text{EP} \quad \boxed{a_1} \\ \text{H-CONS} \quad \boxed{b_1} \\ \text{H-STORE} \quad \boxed{c_1} \end{array} \right] \\ \text{PHON} \quad \boxed{d_1} \end{array} \right\rangle, \dots, \left[\begin{array}{l} \text{SYNSEM|CONT} \left[\begin{array}{l} \text{EP} \quad \boxed{a_n} \\ \text{H-CONS} \quad \boxed{b_n} \\ \text{H-STORE} \quad \boxed{c_n} \end{array} \right] \\ \text{PHON} \quad \boxed{d_n} \end{array} \right] \right\rangle \end{array} \right] \\ \Rightarrow \left[\begin{array}{l} \textit{dom-obj} \\ \text{SYNSEM} \left[\begin{array}{l} \text{CONT} \left[\begin{array}{l} \text{LTOP} \quad \boxed{0} \\ \text{INDEX} \quad \boxed{1} \\ \text{EP} \quad \boxed{a_1} \oplus \dots \oplus \boxed{a_n} \\ \text{H-CONS} \quad \boxed{b_1} \cup \dots \cup \boxed{b_n} \cup \{ \boxed{0} \geq \{ \boxed{2} \} \uplus \boxed{c_1} \uplus \dots \uplus \boxed{c_n} \} \\ \text{H-STORE} \quad \boxed{4} \end{array} \right] \\ \text{CAT} \quad \boxed{3} \end{array} \right] \\ \text{PHON} \quad f(\boxed{d_1}, \dots, \boxed{d_n}) \end{array} \right] \end{array} \right]$$

(25) A handle constraint of the form “ $A \geq B$ ” is satisfied iff

- (i) for each x in B , either A outscopes x or A is coindexed with x , and
- (ii) there is an x in B such that A is coindexed with x .

(26) $\text{partially_compact}(\boxed{K}, \boxed{1}) = \boxed{K} \oplus \langle \text{totally_compact}(\text{cut_left}(\boxed{K}, \boxed{1})) \rangle$

Condition:

$$\boxed{K} : \text{list}([\text{SYNSEM|CAT|EXTRA} \ +])$$

⁵Copestake, Flickinger, and Sag (1997) is an older version of Copestake, Flickinger, Sag, and Pollard (1999). I refer to the former here because the theory that I describe below is more similar to it than it is to the latter, in that it uses the H-STORE feature. The reason why I use this feature will become clear later on.

⁶The symbol “ \uplus ” here designates “the relation of disjoint set union, which is defined exactly like familiar set union, except that its arguments must be disjoint sets (i.e. they must have an empty intersection)” (Manning et al. (1999)).

These definitions of total and partial compaction mean that a quantifier α is obligatorily retrieved from quantifier storage when the domain object that represents α is merged with some other domain object(s) by the total or partial compaction operation. In other words, the proposed theory is making the following claim: when a domain object representing a quantifier α and some other domain object(s) are compacted to produce a new domain object β , either what is signified by β or a part of it becomes the semantic scope of α .

It might be slightly misleading to say that the H-STORE feature is being used as quantifier storage. The quantifier storage mechanism was originally postulated in order to account for the fact that the scope of a quantifier can be larger than the domain that is syntactically c-commanded by that quantifier; it was meant to be a substitute for mechanisms such as Quantifying In and Quantifier Raising. In the theory proposed here, on the other hand, the H-STORE feature is used merely in order to keep track of which domain object represents which quantifiers, not in order to give wide scope to quantifiers. In this theory, the role that is played by mechanisms such as Quantifier Raising in other theories is played by order domains, not by H-STORE values, intuitively speaking.

The undefined function f in the definition of total compaction is meant to be a function that constructs an appropriate prosodic structure out of smaller prosodic constituents. For the sake of concreteness, I assume that the following holds in most cases.

$$(27) f(\boxed{d_1}, \dots, \boxed{d_n}) = \langle \boxed{d_1}, \dots, \boxed{d_n} \rangle$$

In defining the total compaction operation above, I was assuming that the EP value, the H-CONS value, and the H-STORE value of a sign (as opposed to a domain object) are always empty (either an empty list or an empty set). Alternatively, the values of these three features of a sign could be used to represent constructional meaning, that is, meaning that is expressed not by individual words but by grammatical constructions. In that case, the definition of total compaction would have to be slightly modified, as shown in (28).

$$(28) \left[\begin{array}{l} \textit{sign} \\ \left[\begin{array}{l} \text{SYNSEM} \\ \left[\begin{array}{l} \text{CONT} \\ \left[\begin{array}{l} \text{LTOP} \\ \text{INDEX} \\ \text{SEMHEAD} \\ \text{EP} \\ \text{H-CONS} \\ \text{H-STORE} \end{array} \right] \begin{array}{l} \boxed{0} \\ \boxed{1} \\ \boxed{2} \\ \boxed{a_0} \\ \boxed{b_0} \\ \boxed{c_0} \end{array} \end{array} \right] \\ \text{CAT} \quad \boxed{3} \quad \left[\text{TO-BE-STORED} \quad \boxed{4} \right] \end{array} \right] \\ \text{DOM} \left\langle \left[\begin{array}{l} \text{SYNSEM|CONT} \\ \left[\begin{array}{l} \text{EP} \\ \text{H-CONS} \\ \text{H-STORE} \end{array} \right] \begin{array}{l} \boxed{a_1} \\ \boxed{b_1} \\ \boxed{c_1} \end{array} \right] \\ \text{PHON} \quad \boxed{d_1} \end{array} \right], \dots, \left[\begin{array}{l} \text{SYNSEM|CONT} \\ \left[\begin{array}{l} \text{EP} \\ \text{H-CONS} \\ \text{H-STORE} \end{array} \right] \begin{array}{l} \boxed{a_n} \\ \boxed{b_n} \\ \boxed{c_n} \end{array} \right] \\ \text{PHON} \quad \boxed{d_n} \end{array} \right] \right\rangle \end{array} \right] \\ \Rightarrow \left[\begin{array}{l} \textit{dom-obj} \\ \left[\begin{array}{l} \text{SYNSEM} \\ \left[\begin{array}{l} \text{CONT} \\ \left[\begin{array}{l} \text{LTOP} \\ \text{INDEX} \\ \text{EP} \\ \text{H-CONS} \\ \text{H-STORE} \end{array} \right] \begin{array}{l} \boxed{0} \\ \boxed{1} \\ \boxed{a_0 \oplus \dots \oplus a_n} \\ \boxed{b_0 \cup \dots \cup b_n \cup \{ \boxed{0} \geq \{ \boxed{2} \} \uplus \boxed{c_0} \uplus \dots \uplus \boxed{c_n} \}} \\ \boxed{4} \end{array} \right] \\ \text{CAT} \quad \boxed{3} \end{array} \right] \\ \text{PHON} \quad f(\boxed{d_1}, \dots, \boxed{d_n}) \end{array} \right] \end{array} \right]$$

I will rely on the definition in (28) in the remainder of this paper, although it is not entirely clear whether (24) is really inadequate. (I will reconsider the definition of total compaction again in section 5 below.)

In conjunction with the assumption that a tensed sentence is always required to undergo total compaction in English (Kathol and Pollard (1995); Dowty (1996)), the proposed theory provides an explanation for the putative fact that a tensed sentence is always a scope island in English. It is not immediately clear whether this aspect of the proposed theory is its merit or its debit. The putative fact in question has been discussed by Farkas (1981), Fox and Sauerland (1996), Farkas and Giannakidou (1996), Reinhart (1997), Dalrymple et al. (1999), Partee (1999), Fox (2000), and Steedman (2000), among others, and some of these authors repudiate the claim that a tensed sentence is always a scope island in English. Resolution of this issue is beyond the scope of this paper.

An English sentence like (29) might appear to contradict a prediction made by the proposed theory.

(29) Everyone_i's mother thinks he_i's a genius. (From Reinhart (1983))

The fact that a possessive phrase like *everyone's* in front of a nominal like *mother* is never extrapositionable means that the domain object representing a possessive phrase and the domain object representing the nominal immediately following that possessive phrase always undergo total compaction together to produce a single domain object. This would appear to mean, within the proposed theory, that a possessive phrase always had to take scope within the smallest NP containing it (the NP *everyone's mother*, in the case of the sentence in question). This apparent prediction obviously contradicts the fact that the possessive phrase in (29) seems to take scope over the matrix clause. Does this mean that the theory is incorrect? It does not, for the following reason. It is conceivable that what is actually functioning as a quantifier in (29) is the subject NP as a whole (*everyone's mother*), rather than the NP *everyone* alone. In other words, it is conceivable that English has what might be called *quantificational pied-piping*, which allows a phrase properly containing what looks like a quantifier to function as a quantifier instead.⁷

I need to assume that the relation between the meaning of an expression and the feature structure representation of that expression is somewhat indirect; more specifically, I have to assume that the meaning of a sign α is the CONTENT value⁸ of the domain object that is obtained by totally compacting α . (See (33) and (34) below for an illustration of what this means.) Since on this account the meaning of a sign is not directly represented anywhere within the sign itself, use of the term *sign* in the present context is probably out of place to some extent, if a “sign” is to be understood as a combination of sound and meaning.

Likewise, I need to assume that lexical threading of stored quantifiers (as described by Pollard and Yoo (1998)) does not take place or takes place only optionally. For the sake of concreteness, let me assume that it does not take place at all.⁹

I wish to emphasize here the naturalness of the idea that meaning assembly is “compaction-driven” in the way that I describe here, that is, the idea that semantic composition is carried out on the basis of prosodic (rather than syntactic) structure. On one hand, in a linearization-based theory, syntactic phrase structure trees do not represent linear order between constituents; linear order is assumed to be present only in order domains. On the other hand, it is almost certain that the meaning of a phrase is affected to a certain extent by the linear precedence relations that hold between its constituents. In light of these two observations, I believe that, at least in the context of linearization-based syntax, the idea of compaction-driven meaning assembly is in fact more plausible than the traditional view, according to which semantic composition is to be carried out on the basis of syntactic (rather than prosodic) structure.

Several more things need to be said in order for the proposed theory to work. Those things are stated in (30), (31), and (32). (30) states constraints on the relation between the order domain of a phrase and the order domains of its daughters; (31) states constraints on the values of the LTOP feature and the SEMHEAD feature; and (32) states linear precedence constraints. It is mainly what is stated in (30e) that captures the contrast between (11) and (12) above. One terminological comment is in order. An expression may undergo no compaction whatsoever and contribute all the domain objects in its order domain to the order domain of its mother. I describe such a situation by saying that the expression in question has been *liberated*.

(30) a. In a head-complement structure whose head is verbal, the head is liberated and the non-head is partially compacted.

⁷See Bach and Partee (1980) and Yatabe (1993, subsection 4.2.2).

⁸I ignore the CONTEXT feature altogether in this paper.

⁹This move is independently motivated by the kinds of observations made in Lasnik (1999).

- b. In a head-adjunct structure whose head is verbal, the head and the adjunct are both partially compacted.
 - c. In a headed structure whose head is nominal and whose non-head is not a marker, the head is totally compacted and the non-head is partially compacted.
 - d. In a head-marker structure, the head and the marker are both liberated.
 - e. In a coordinate structure, each of the conjuncts is totally compacted.
- (31) a. The LTOP value and the SEMHEAD value of a headed structure whose head is liberated are identical to the LTOP value and the SEMHEAD value of the head respectively.
- b. The SEMHEAD value of a head-complement structure whose head is totally or partially compacted is identical to the LTOP value of the head.
 - c. The SEMHEAD value of a head-adjunct structure whose head is totally or partially compacted is identical to the LTOP value of the non-head.
 - d. The SEMHEAD value of a coordinate structure is identical to the HNDL value of the elementary predication that is constructionally introduced by that coordinate structure (i.e. the elementary predication whose RELN value is something like *or*).
- (32) a. [SYNSEM 1] < [SYNSEM|CAT|COMPS <...1...>]
- b. [SYNSEM|CAT|HEAD|MOD 1] < [SYNSEM 1]

Note that (30) is intended to be subordinate to (19), as should be clear from what is stated in (19). Thus, each conjunct in a coordinate structure is required to undergo total compaction in its entirety only when the coordinate structure does not undergo node raising. When a coordinate structure does undergo node raising, only the portion of each conjunct which was not node-raised undergoes compaction.¹⁰

The way the proposed analysis works for the simple sentence in (33) is illustrated in (34). In this illustration, I abbreviate SYNSEM as SS and CONT(ENT) as CN.

- (33) Tarô ga nana-satsu-ijô no hon o yonda.
 Tarô NOM 7 or more volumes GEN book ACC read-PAST
 ‘Tarô read seven or more books.’

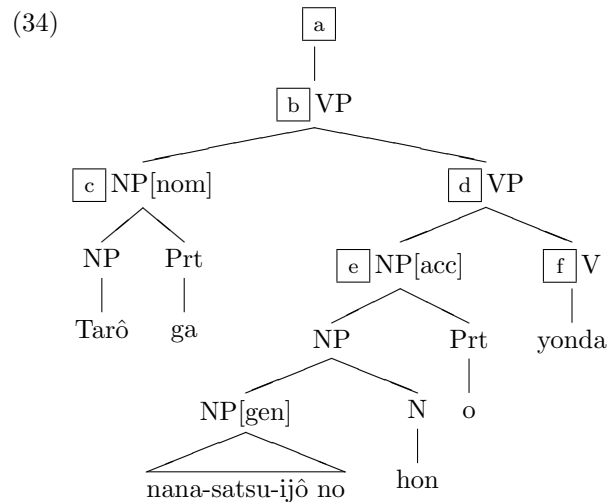

¹⁰Kathol (1995) presents a linearization-based analysis of coordination that is different from, and fundamentally incompatible with the analysis proposed here. Detailed comparison of the two is beyond the scope of this paper.

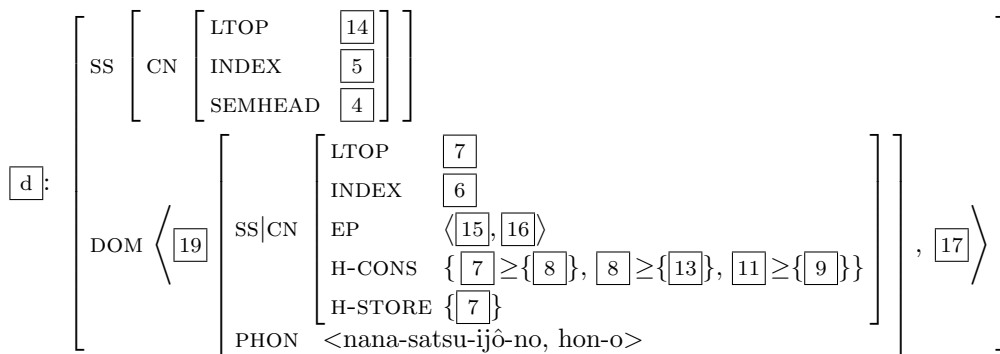
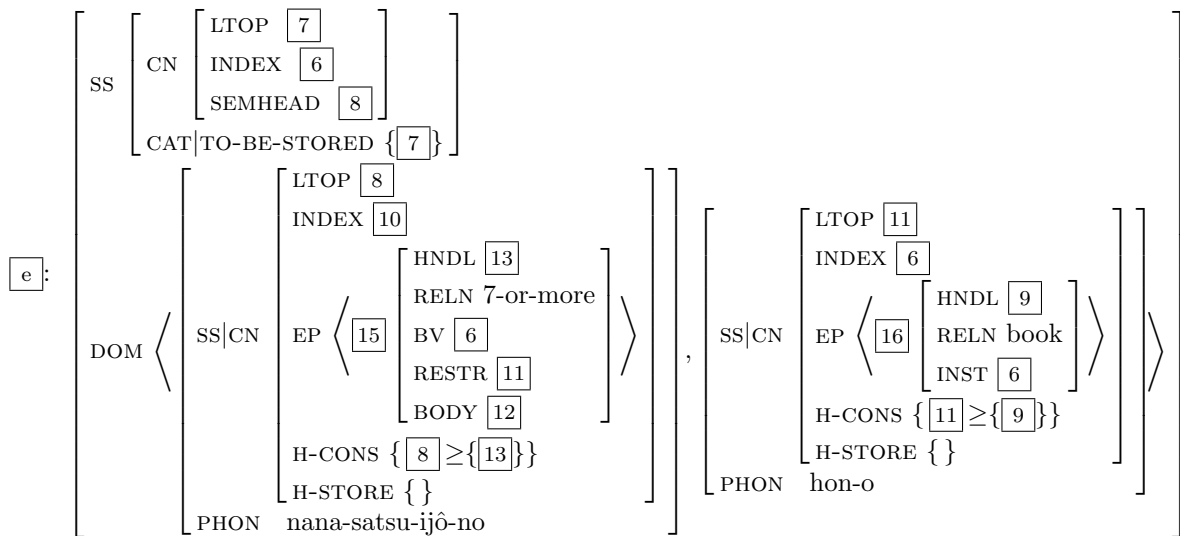
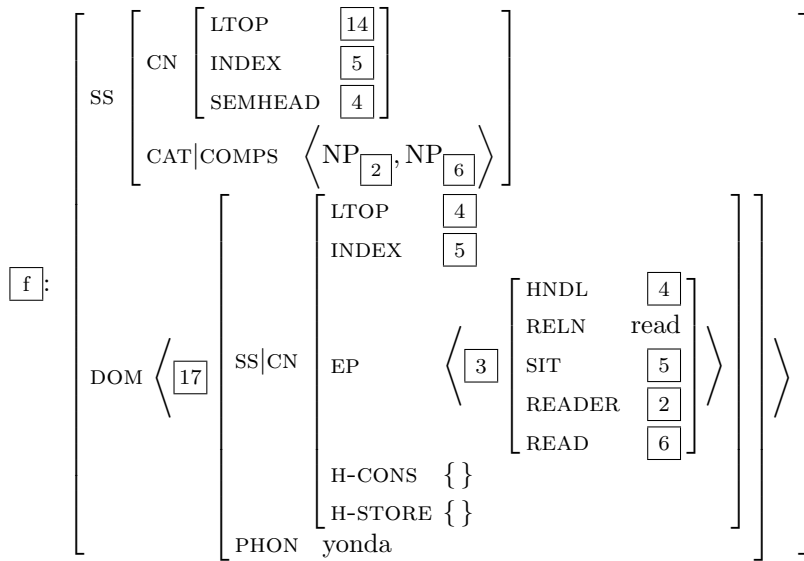

$$\begin{array}{c}
\boxed{c}: \\
\left[\begin{array}{c}
\text{SS} \left[\begin{array}{c} \text{CN} \left[\begin{array}{c} \text{LTOP} \quad \boxed{14} \\ \text{INDEX} \quad \boxed{2} \\ \text{SEMHEAD} \quad \boxed{1} \end{array} \right] \right] \\
\text{DOM} \left\langle \begin{array}{c} \text{SS|CN} \left[\begin{array}{c} \text{LTOP} \quad \boxed{1} \\ \text{INDEX} \quad \boxed{2} \\ \text{EP} \quad \langle \boxed{18} \rangle \\ \text{H-CONS} \quad \{ \} \\ \text{H-STORE} \quad \{ \} \end{array} \right] \\ \text{PHON} \quad \text{Tarô-ga} \end{array} \right\rangle \left\langle \begin{array}{c} \text{HNDL} \quad \boxed{1} \\ \text{RELN} \quad \text{name} \\ \text{NAME} \quad \text{Tarô} \\ \text{NAMED} \quad \boxed{2} \end{array} \right\rangle \right\rangle
\end{array} \right] \\
\\
\boxed{b}: \\
\left[\begin{array}{c}
\text{SS} \left[\begin{array}{c} \text{CN} \left[\begin{array}{c} \text{LTOP} \quad \boxed{14} \\ \text{INDEX} \quad \boxed{5} \\ \text{SEMHEAD} \quad \boxed{4} \end{array} \right] \right] \\
\text{DOM} \left\langle \begin{array}{c} \text{SS|CN} \left[\begin{array}{c} \text{LTOP} \quad \boxed{14} \\ \text{INDEX} \quad \boxed{2} \\ \text{EP} \quad \langle \boxed{18} \rangle \\ \text{H-CONS} \quad \{ \boxed{14} \geq \{ \boxed{1} \} \} \\ \text{H-STORE} \quad \{ \} \end{array} \right] \\ \text{PHON} \quad \text{Tarô-ga} \end{array} \right\rangle \left\langle \boxed{19}, \boxed{17} \right\rangle
\end{array} \right] \\
\\
\boxed{a} = \text{totally_compact}(\boxed{b}) \\
= \left[\begin{array}{c}
\text{dom-obj} \\
\text{SS|CN} \left[\begin{array}{c} \text{LTOP} \quad \boxed{14} \\ \text{INDEX} \quad \boxed{5} \\ \text{EP} \quad \langle \boxed{18}, \boxed{15}, \boxed{16}, \boxed{3} \rangle \\ \text{H-CONS} \quad \{ \boxed{14} \geq \{ \boxed{4}, \boxed{7} \}, \boxed{14} \geq \{ \boxed{1} \}, \boxed{7} \geq \{ \boxed{8} \}, \boxed{8} \geq \{ \boxed{13} \}, \boxed{11} \geq \{ \boxed{9} \} \} \\ \text{H-STORE} \quad \{ \} \end{array} \right] \\
\text{PHON} \quad \langle \text{Tarô-ga}, \langle \text{nana-satsu-ijô-no}, \text{hon-o} \rangle, \text{yonda} \rangle
\end{array} \right]
\end{array}$$

The EP value and the H-CONS value of the top node in (34), which supposedly express the core of the meaning of (33), are shown in linear form in (35a) and (35b) respectively. (I ignore the situation (SIT) argument of the *read* relation here.)

- (35) a. $\langle h1: \text{name}(\text{Tarô}, x), h13: \text{seven-or-more}(y, h11, h12), h9: \text{book}(y), h4: \text{read}(x, y) \rangle$
b. $\{ h14 \geq \{ h4, h7 \}, h14 \geq \{ h1 \}, h7 \geq \{ h8 \}, h8 \geq \{ h13 \}, h11 \geq \{ h9 \} \}$

$h14$ is the top handle. There is only one way to resolve this MRS structure: it must be the case that $h14 = h7 = h1 = h8 = h13$ and $h11 = h9$ and $h12 = h4$. The meaning of this scope-resolved MRS corresponds to what the sentence in question is intuitively felt to mean.

In this theory, the contrast between (11) and (12) receives the following explanation. In (11), which does not involve left-node raising, each conjunct is totally compacted, due to (30e). As a result, the quantifier *nana-satsu-ijô no hon* ‘seven or more books’, which is contained in the first conjunct, has to take scope within that conjunct, thus necessarily allowing the disjunction to take wide scope over it. In the case of (12), on the other hand, the quantifier in question is left-node-raised out of the coordinate structure. The following two scenarios are both possible in this case: the quantifier will take wide scope over the disjunction if what has been left-node-raised is a domain object, and the quantifier will remain within the scope of the disjunction if

what has been left-node-raised is not a domain object but a prosodic constituent contained inside a domain object. (36) below illustrates the structure that (12) is claimed to have when what is involved is LNR of a domain object. (I assume that *shinakereba naranai* is a V, to simplify the illustration.)

(36) [PHON “nana-satsu-ijô no hon no shohyô o kaku ka yôyaku o sakusei suru ka shinakereba naranai”]

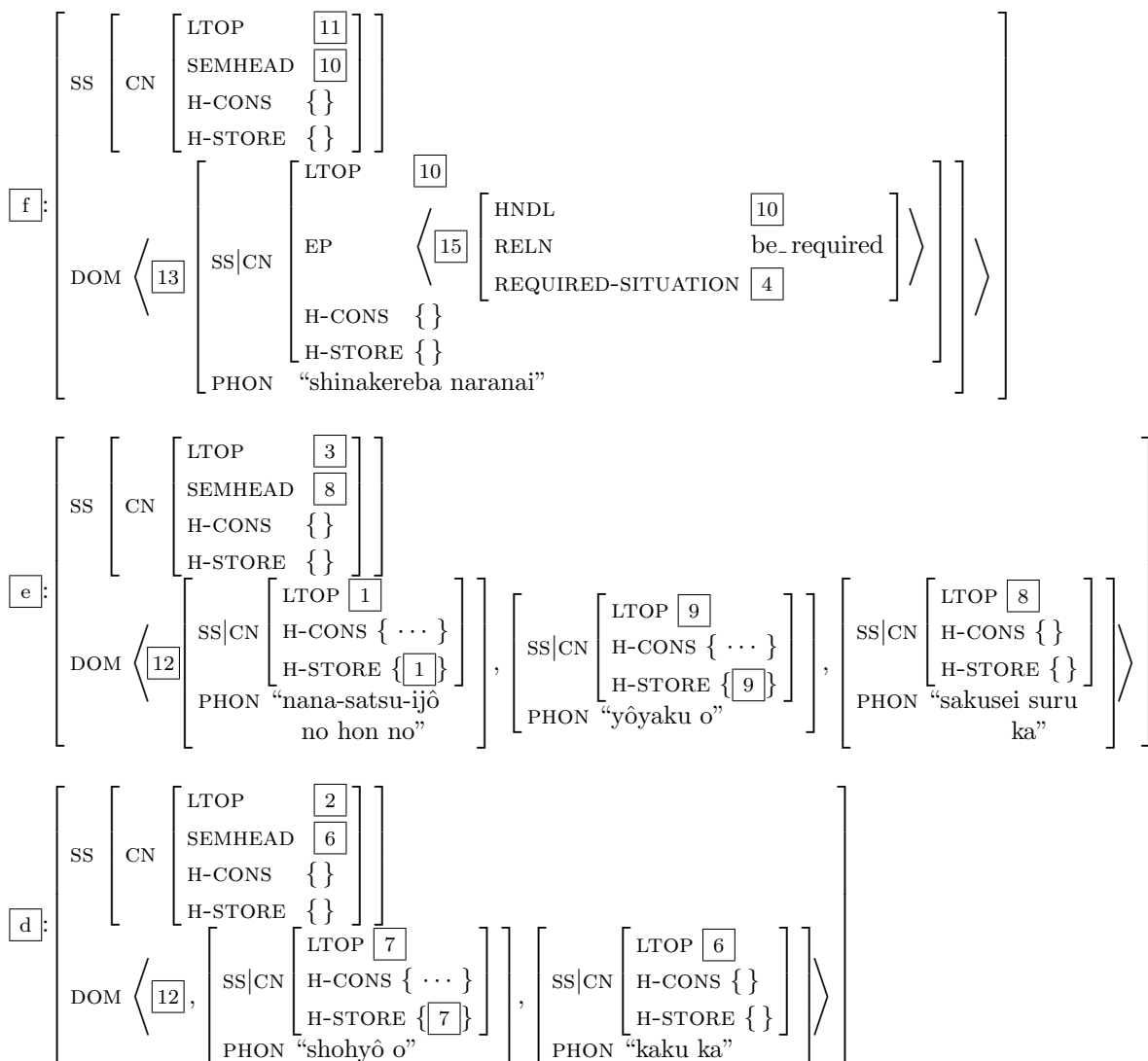
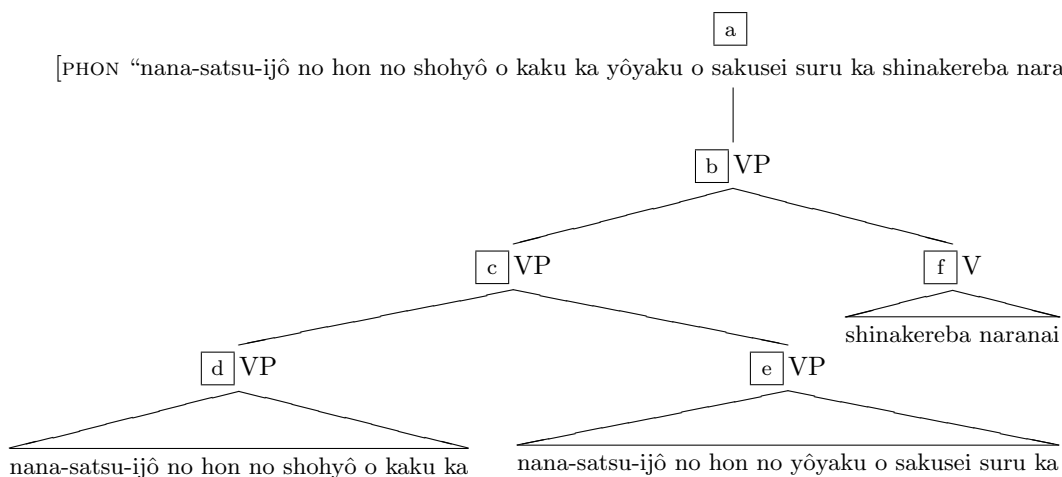

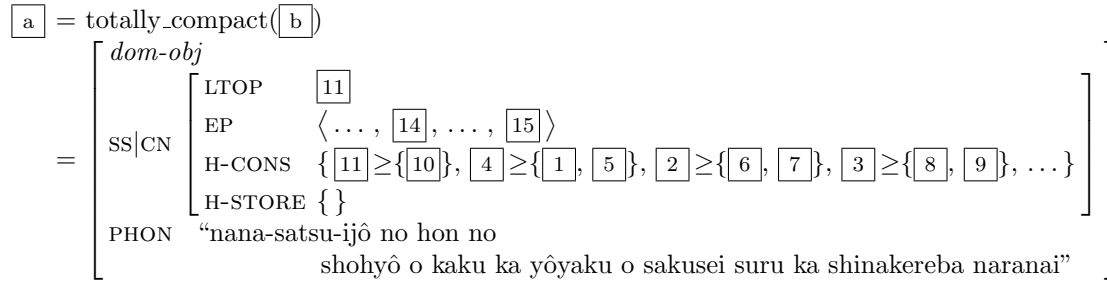
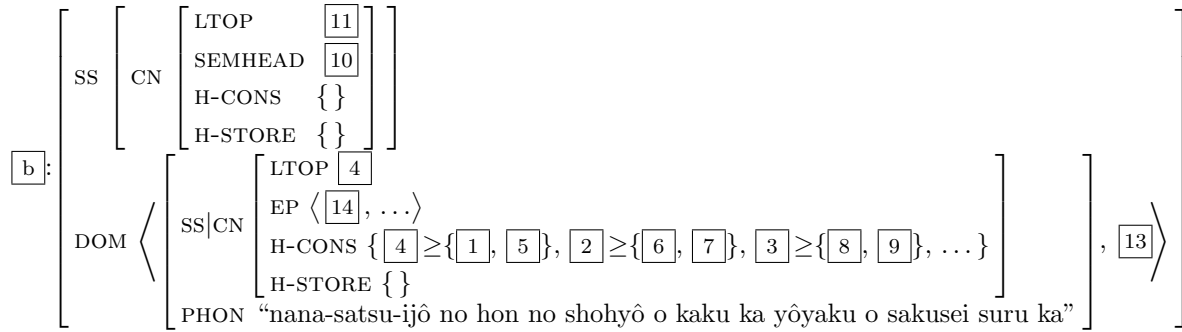
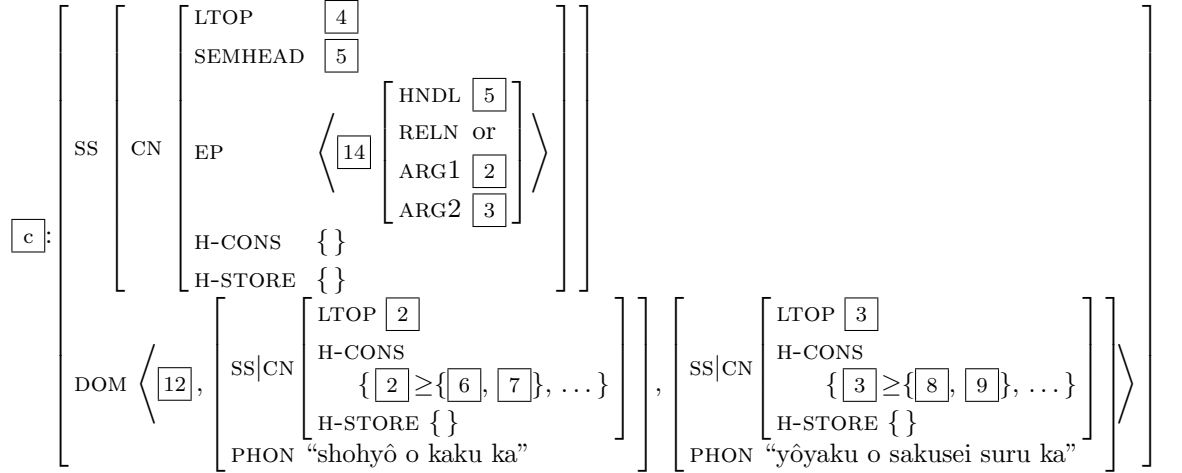

In this illustration, I suppress the internal structure of PHON values. For the sake of concreteness, I assume here that the two bare NPs in (12), namely *nana-satsu-ijô no hon no shohyô o* and *nana-satsu-ijô no hon no yôyaku o*,¹¹ are interpreted as quantifiers, perhaps roughly paraphrasable as “one or more reviews of seven or more books” and “one or more summaries of seven or more books” respectively. Another crucial assumption here is that genitive NPs in Japanese (those NPs that end with the particle *no*) are marked as [EXTRA +], and hence are extraposable (see (26) above).¹²

The reason why I have chosen not to eliminate the H-STORE feature should now be clear. Although there is no need to use it to give wide scope to quantifiers anymore, I need the feature in order to capture and state syntactic constraints on quantifier scoping.

The proposed theory of semantic composition not only successfully captures the semantic property of LNR in Japanese but also remedies a defect in Kathol and Pollard’s (1995) analysis of extraposition. As noted by Guéron (1980) with regard to an example like (37), extraposition of PP sometimes affects semantic scope relations. This fact, which is left unexplained in Kathol and Pollard’s account, receives a natural explanation in the proposed theory.

¹¹Since the phrase *nana-satsu-ijô no* ‘seven or more’ is modifying the noun *hon* ‘book’ rather than *shohyô* ‘review’ or *yôyaku* ‘summary’, the two NPs in question are indeed bare NPs, i.e. NPs without any determiner-like elements.

¹²See Yatabe (1993; 1996) for evidence that genitive NPs in Japanese are extraposable.

(37) ??The owner will be fined of every car on the block. (from Guéron (1980))

It has been brought to my attention that (37) is a very awkward sentence, but the Japanese sentence in (38) is only slightly awkward and serves to make the same point.

(38) [Dare ni mo] Ken wa [Naomi ga awanakatta to] iwanakatta.
 [who DAT also] Ken TOP [Naomi NOM see-NEG-PAST COMP] say-NEG-PAST
 ‘Ken said of nobody that Naomi had not seen that person.’

This example is a result of extraposing a dative NP *dare ni mo*, which functions as a quantifier that means ‘anybody’, out of the embedded clause,¹³ and its meaning is different from the meaning of the sentence in (39), which does not involve extraposition.

(39) Ken wa [Naomi ga [dare ni mo] awanakatta to] iwanakatta.
 Ken TOP [Naomi NOM [who DAT also] see-NEG-PAST COMP] say-NEG-PAST
 ‘Ken did not say that Naomi hadn’t seen anybody.’

5 Two potential problems

Let me mention briefly two potential problems for the proposed account.

One problem is posed by a sentence like (40a), whose interpretation is not correctly captured by the proposed theory.

- (40) (from Abbott (1976))
- a. I borrowed, and my sister stole, a total of \$3000 from the bank.
 - b. I borrowed a total of \$3000 from the bank and my sister stole a total of \$3000 from the bank.

(40a) and (40b) mean different things. This is another piece of evidence that node raising can affect meaning, and as such it should lend additional support to the theory proposed in this paper. The theory as it is presented here, however, does not correctly capture the meaning of (40a). The Japanese example in (41) arguably demonstrates that the same problem arises in the case of LNR as well, although it is possible that this sentence is a case of constituent coordination and does not involve LNR. (I have been unable to construct a relevant example in Japanese that unambiguously involves LNR and does not sound too unnatural.)

(41) GÔKEI JÛNANA-SATSU NO HON O, <Ken wa genkin de kai>, <Naomi wa kâdo
 total 17 volumes GEN book ACC <Ken TOP cash INST buy-CONT> <Naomi TOP credit card
 de katta.>
 INST buy-PAST>
 ‘Ken bought for cash, and Naomi bought on credit, a total of seventeen books.’

I will not go into the details of this problem any further here, because I feel that this is a problem that will eventually be resolved by refining our theory of mass NPs and plural NPs, not by tinkering with the theory of node raising.

Another potential problem concerns the fact that my analysis as it stands now does not require that prosodic constituents that are merged and node-raised together have identical semantic content. As a result, the theory allows two homophonous words, for instance *kumo* ‘cloud’ and *kumo* ‘spider’ to be node-raised together as if they were the same word. Intuitively, this is not the way things should be; LNR and RNR should be possible only when the node-raised elements share identical semantic content, no matter whether the node-raised elements are domain objects or prosodic constituents properly contained within domain objects. Such an additional restriction on node-raising of prosodic constituents could be incorporated into the proposed theory by adding some semantic information to the values of the PHON feature. This could be done by (i) adding semantic information to the PHON value of each lexical entry, as in (42), (ii) slightly modifying the definition of total compaction, as shown in (43), and (iii) modifying the definition of *chop-left* (see (23) above) as shown in (44).¹⁴

¹³For arguments that this sentence involves extraposition rather than unbounded dependency, see Yatabe (1996).

¹⁴*add. synsem* (see (22) above) needs to be revised accordingly, too.

(42) The lexical entry for *yonda* ‘read’

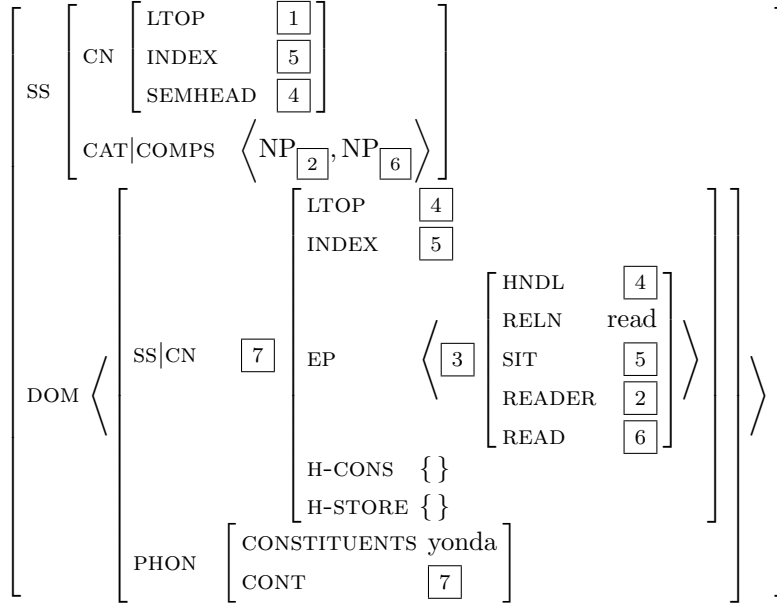

(43) Total compaction (version 3):

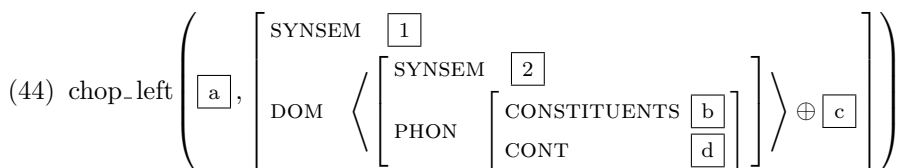
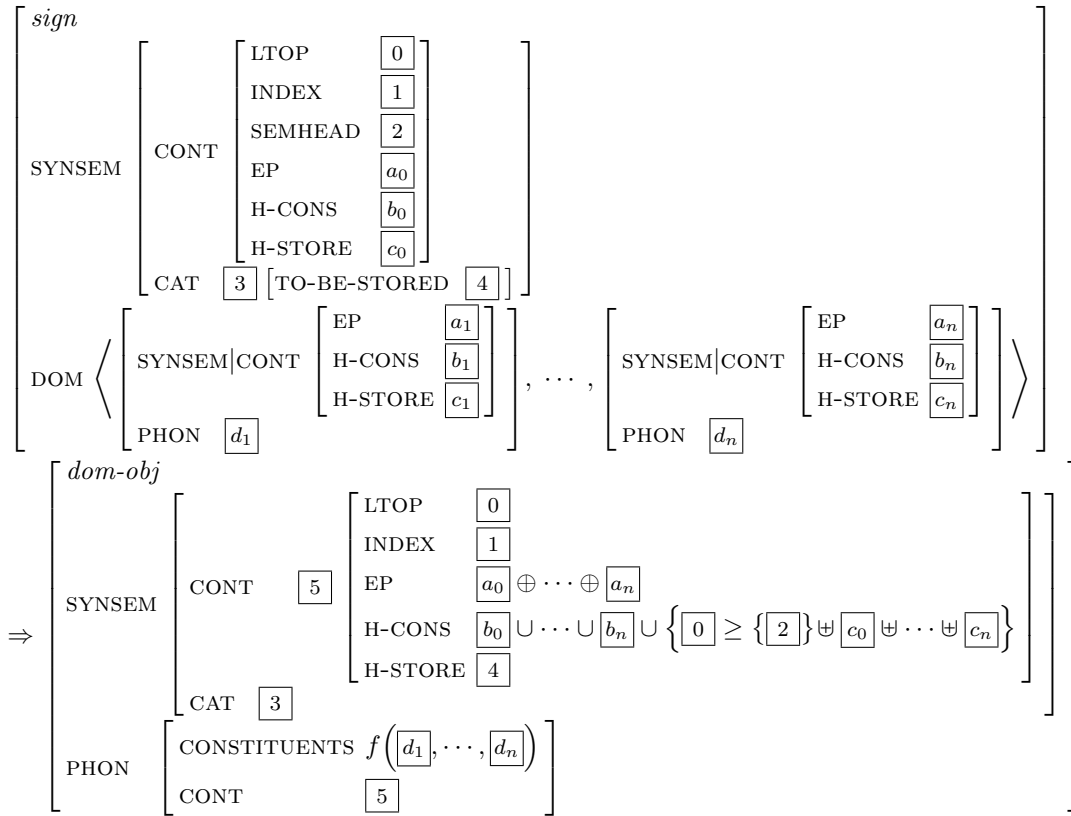

$$= \left[\begin{array}{l} \text{SYNSEM} \quad \boxed{1} \\ \text{DOM} \left\langle \begin{array}{l} \text{SYNSEM} \quad \boxed{2} \\ \text{PHON} \quad \left[\begin{array}{l} \text{CONSTITUENTS} \text{ subtract_left}(\boxed{a}, \boxed{b}) \\ \text{CONT} \quad \boxed{d} \end{array} \right] \end{array} \right\rangle \oplus \boxed{c} \end{array} \right]$$

This revised analysis, however, may not be without its problems. Besides the fact that the new feature geometry is unnecessarily redundant and calls for some simplification, the new analysis might run into problems with respect to what Jacobson (1996; 1999) calls *cross-the-board binding*, that is, binding of one pronoun by more than one binder. (45) exemplifies the phenomenon.

- (45) JIBUN-JISHIN NO SEIKÔ O HANA NI <kakeru hito> to <kakenai hito>
 self-self GEN success ACC nose DAT <hang-PRES person> and <hang-NEG-PRES person>
 ga iru.
 NOM be-PRES

‘There are people who hang their own success on their nose as well as people who don’t.’ (lit.)
 ‘There are people who are complacent about their own success as well as people who aren’t.’

In this sentence, the reflexive pronoun *jibun-jishin* is bound by the unexpressed subject of *kakeru* as well as that of *kakenai*. Unlike the original analysis, the revised analysis will systematically fail to generate sentences of this type, if it is assumed that two NPs can be coindexed only when they are “coreferential” in the broad sense of the term. I need to assume that “accidental coindexing” of two quantifiers is not disallowed, at the very least. At the moment, it is not clear to me whether that is all that needs to be done.

6 Conclusion

I have shown that there are what might be called *left-node raising constructions* in Japanese. In order to capture the syntactic and semantic properties of those constructions, I have proposed a linearization-based theory in which prosodic constituency is represented in order domains and the CONTENT values of domain objects are taken to be the primary locus of semantic composition. I have argued that the proposed theory is instrumental in accounting for some hitherto unexplained properties of *extraposition constructions* and *right-node raising constructions* in languages like English as well.

Acknowledgments

I would like to thank the three anonymous reviewers for the HPSG-2000 conference as well as the audience at the conference for helpful comments.

References

- Abbott, Barbara: 1976, ‘Right node raising as a test for constituenthood,’ *Linguistic Inquiry*, 7, pp. 639–642.
 Bach, Emmon and Barbara H. Partee: 1980, ‘Anaphora and semantic structure,’ in Jody Kreiman and Almerindo E. Ojeda, eds., *Papers from the Parasession on Pronouns and Anaphora*, CLS, Chicago, pp. 1–28.
 Booij, Geert E.: 1984, ‘Coordination reduction in complex words: a case for prosodic phonology,’ in Harry van der Hulst and Norval Smith, eds., *Advances in Nonlinear Phonology*, Foris, Dordrecht, pp. 143–160.
 Copestake, Ann, Dan Flickinger, and Ivan A. Sag: 1997, ‘Minimal recursion semantics: an introduction,’ ms., Stanford University, Stanford.
 Copestake, Ann, Dan Flickinger, Ivan A. Sag, and Carl Pollard: 1999, ‘Minimal recursion semantics: an introduction,’ ms., Stanford University, Stanford.
 Dalrymple, Mary, John Lamping, Fernando Pereira, and Vijay Saraswat: 1999, ‘Quantification, anaphora, and intentionality,’ in Mary Dalrymple, ed., *Semantics and Syntax in Lexical Functional Grammar: The Resource Logic Approach*, MIT Press, Cambridge, Massachusetts, pp. 39–89.
 Donohue, Cathryn, and Ivan Sag: 1999, ‘Domains in Warlpiri,’ abstract for the talk presented at the 6th International Conference on HPSG, University of Edinburgh.

- Dowty, David, R.: 1996, 'Toward a minimalist theory of syntactic structure,' in Harry Bunt and Arthur van Horck, eds., *Discontinuous Constituency*, Mouton de Gruyter, Berlin, pp. 11–62.
- Farkas, Donka: 1981, 'Quantifier scope and syntactic islands,' in Roberta A. Hendrick, Carrie S. Masek, and Mary Frances Miller, eds., *Papers from the Seventeenth Regional Meeting, Chicago Linguistic Society*, CLS, Chicago, pp. 59–66.
- Farkas, Donka F., and Anastasia Giannakidou: 1996, 'How clause-bounded is the scope of universals?' in Teresa Galloway and Justin Spence, eds., *Semantics and Linguistic Theory VI*, CLC Publications, Cornell University, Ithaca, pp. 35–52.
- Fox, Danny: 2000, *Economy and Semantic Interpretation*, MIT Press, Cambridge, Massachusetts.
- Fox, Danny, and Uli Sauerland: 1996, 'Illusive scope of universal quantifiers,' in Kiyomi Kusumoto, ed., *Proceedings of the North East Linguistic Society 26*, GLSA, University of Massachusetts, Amherst, pp. 71–85.
- Guéron, Jacqueline: 1980, 'On the syntax and semantics of PP extraposition,' *Linguistic Inquiry*, 11, pp. 637–678.
- Hudson, Richard: 1976, 'Conjunction reduction, gapping, and right-node-raising,' *Language*, 52, pp. 535–562.
- Jacobson, Pauline: 1996, 'The locality of interpretation: the case of binding and coordination,' in Teresa Galloway and Justin Spence, eds., *Proceedings from Semantics and Linguistic Theory VI*, CLC Publications, Ithaca, pp. 111–135.
- Jacobson, Pauline: 1999, 'Towards a variable-free semantics,' *Linguistics and Philosophy*, 22, pp. 117–184.
- Kathol, Andreas: 1995, *Linearization-Based German Syntax*, Ph.D. dissertation, Ohio State University, Columbus.
- Kathol, Andreas, and Carl Pollard: 1995, 'Extraposition via complex domain formation,' in *33rd Annual Meeting of the Association for Computational Linguistics*, Morgan Kaufmann, San Francisco, pp. 174–180.
- Kehler, Andrew, Mary Dalrymple, John Lamping, and Vijay Saraswat: 1999, 'Resource sharing in glue language semantics,' in Mary Dalrymple, ed., *Semantics and Syntax in Lexical Functional Grammar: The Resource Logic Approach*, MIT Press, Cambridge, Massachusetts, pp. 191–208.
- Lasnik, Howard: 1999, 'Chains of arguments,' in Samuel David Epstein and Norbert Hornstein, eds., *Working Minimalism*, MIT Press, Cambridge, Massachusetts, pp. 189–215.
- Manning, Christopher D., Ivan A. Sag, and Masayo Iida: 1999, 'The lexical integrity of Japanese causatives,' in Robert D. Levine and Georgia M. Green, eds., *Studies in Contemporary Phrase Structure Grammar*, Cambridge University Press, Cambridge, pp. 39–79.
- McCawley, James D.: 1982, 'Parentheticals and discontinuous constituent structure,' *Linguistic Inquiry*, 13, pp. 91–106.
- Nunberg, Geoffrey, Ivan A. Sag, and Thomas Wasow: 1994, 'Idioms,' *Language*, 70, pp. 491–538.
- Partee, Barbara H.: 1999, 'Focus, quantification, and semantics-pragmatics issues,' in Peter Bosch and Rob van der Sandt, eds., *Focus: Linguistic, Cognitive, and Computational Perspectives*, Cambridge University Press, Cambridge, pp. 213–231.
- Pollard, Carl and Eun Jung Yoo: 1998, 'A unified theory of scope for quantifiers and *wh*-phrases,' *Journal of Linguistics*, 34, pp. 415–445.
- Poser, William J.: 1990, 'Word-internal phrase boundary in Japanese,' in Sharon Inkelas and Draga Zec, eds., *The Phonology-Syntax Connection*, University of Chicago Press, Chicago, pp. 279–287.
- Reinhart, Tanya: 1983, *Anaphora and Semantic Interpretation*, Croom Helm, London.
- Reinhart, Tanya: 1997, 'Quantifier scope: how labor is divided between QR and choice functions,' *Linguistics and Philosophy*, 20, pp. 335–397.
- Steedman, Mark: 2000, *The Syntactic Process*, MIT Press, Cambridge, Massachusetts.
- Wilder, Chris: 1997, 'Some properties of ellipsis in coordination,' in Artemis Alexiadou and T. Alan Hall, eds., *Studies on Universal Grammar and Typological Variation*, John Benjamins, Amsterdam, pp. 59–107.
- Yatabe, Shūichi: 1993, *Scrambling and Japanese Phrase Structure*, Ph.D. dissertation, Stanford University, Stanford.
- Yatabe, Shūichi: 1996, 'Long-distance scrambling via partial compaction,' in Masatoshi Koizumi, Masayuki Oishi, and Uli Sauerland, eds., *Formal Approaches to Japanese Linguistics 2 (MIT Working Papers in Linguistics 29)*, MITWPL, Cambridge, Massachusetts, pp. 303–317.
- Yatabe, Shūichi: 1998, 'Nihongo ni okeru hitei-ji, ryōka-shi no sukōpu no kettei [Determination of the scope of negators and quantifiers in Japanese],' in *Jōchi Daigaku Gengo Gakkai Kaihō (Proceedings of Sophia University Linguistic Society)*, no. 13, pp. 117–136.

Department of Language and Information Sciences
 University of Tokyo
 3-8-1 Komaba, Meguro-ku
 Tokyo, 153-8902, Japan

yatabe@boz.c.u-tokyo.ac.jp
<http://gamp.c.u-tokyo.ac.jp/yatabe/>